



Electrical Distributors

Hardware & Installation Manual

Introduction

The Enermax+ three phase Energy & Demand meter from Strike Technologies measures four quadrants of power and energy and is fully user-configurable with a large memory capacity to retain significant amounts of data. Time of use metering, powerful data profiling, multi function inputs & outputs, comprehensive audit facilities and many other features are provided.

Two docking bays are available to accept any of the several expansion modules available allowing users to customise the meters for their own particular needs. These modules provide communication facilities via RS232, RS484, PSTN or GSM, plus I/O ports to increase the standard meters onboard inputs and outputs when required.

This document details the necessary information for the correct installation together with the specifications and an outline of the functions and default parameters of the Enermax+ meter default settings.

Should the customer have requested a special configuration, the details of this will be listed in a separate document supplied with the meter.

In order to fully utilize the host of metering functions provided, the PC application software package "Eman Plus" is available. This comprehensive software allows convenient configuring of the various options and parameters as well as for reading of meter data.



Overview

Figure 1: Front view with cover removed

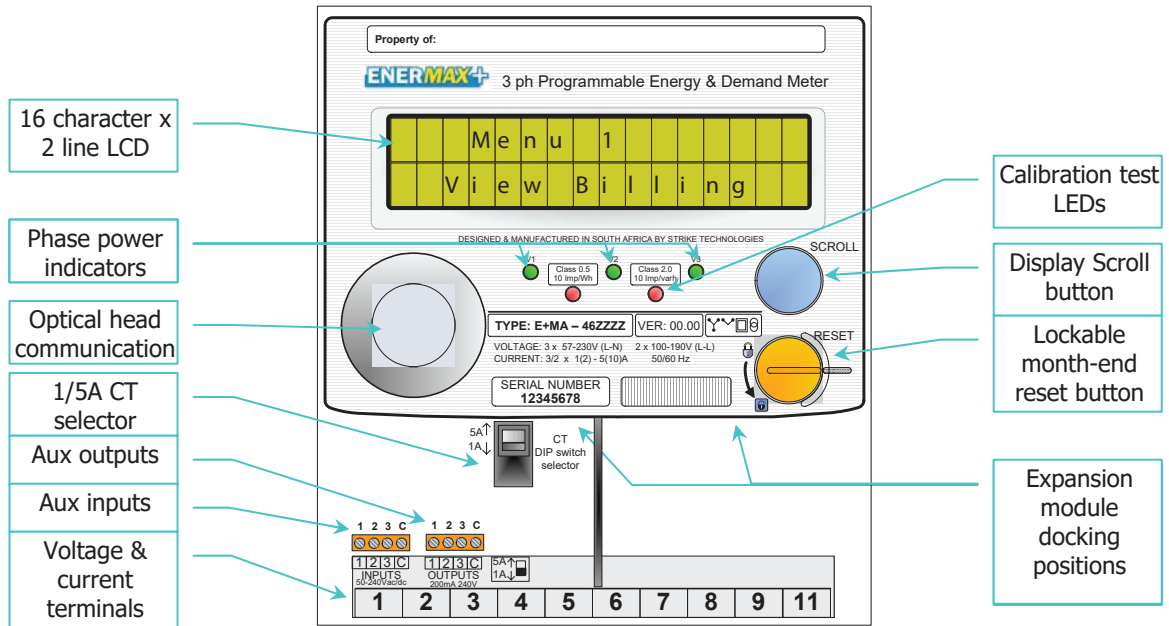

16 x 2 line LCD	Displays information regarding stored & running data, meter status and menu feedback.
Phase power LEDs	3 Green LEDs which indicate that line voltages are above individually programmable thresholds.
Calibration test LEDs	2 Red LEDs which flash at a prescribed rate to enable the accuracy of the meter to be checked.
Optical window	To which to attach a standard optical communication device.
Scroll button	Use this to scroll through the menus displayed on the LCD.
Reset button	Used to manually reset the meter at month end or to select between menus. Rotate to lock.
1/5A CT selector	Set to suit the nominal secondary current rating of the current transformers used.
I/O connectors	Provide various digital input / output capabilities for the meter.
Module sockets	Accept various expansion modules for communication and extra I/O.

Installation

Unpacking

The Enermax+ is shipped in a moulded shock absorbent package, first ensure that there is no obvious mechanical breakage. Should the meter have been supplied to the customer’s special configuration, there will also be a separate sheet listing these details.

Mounting the Meter

The Enermax+ should be mounted as close as possible to the feeder circuits to be measured, according to recognised standards, in an environmentally friendly situation. Do not position in direct sunlight as this may cause overheating. The meter should be attached to a flat, stable surface such as a wall, board, or in a cabinet. Use 6mm bolts through the bracket at the top and two mounting holes in the lower body to mount the meter. When the meter is shipped, the upper bracket is in its stowed position. It may be used in this position to save space. Alternatively it can first be unscrewed and remounted in its extended position. Refer to Figure 2

Figure 2: Bracket in space-saving and extended positions



To access the lower mounting holes, first remove the front cover by undoing the two screws on the front of the meter and pulling the cover away from the body. This also allows access to the connection terminals and extension modules.

Figure 3: Lower mounting holes



Wiring

The various meter models are capable of measuring energy and demand in 3 or 4 wire systems, and should be wired accordingly. Refer to diagrams at the end of this document for wiring examples.

Depending upon the voltage of the system and the rating of the meter, voltage transformers may be required for the voltage inputs. Be aware of the difference between the meter’s ratings for Line-Neutral and Line-Line voltages.



Ensure that you have the correct meter for your system/application before connecting wiring.

Figure 4: Meter Connections

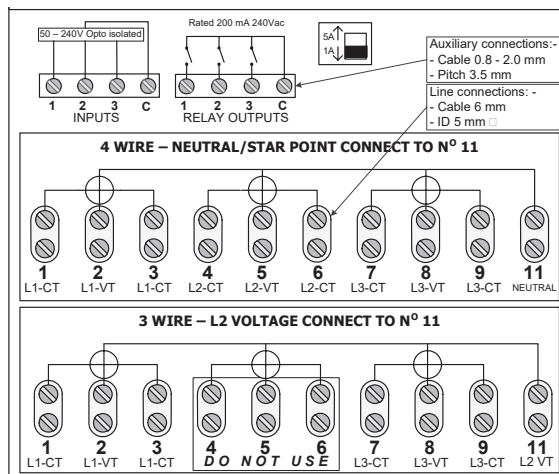

In all instances ensure that the CT selector switch is set to suit the nominal currents of the current transformers used. Wiring of the standard inputs and outputs should be carried out according to their functions and system requirements.

Powering Up the Meter

When supplied with power, the green LED within the optical communication window will light. Three green LEDs labelled L1, L2, and L3 on the front of the meter will light if the line voltages are within specification.

Upon first power up of the meter a start up screen will be displayed for a few moments. Thereafter screen 1 of Menu 1 will appear.

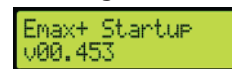

Understanding and Navigating the Menus

There are 16 menus in the Emax+, each one with a series of screens supplying you with information about the electrical system being monitored, and the meter itself. Menus 1 to 8 are user programmable; menus 9 to 16 are factory set and non-programmable. For your convenience menus 1 and 2 have been pre-programmed for the two most common requirements, kWh & Block Demand, and kWh & Thermal Demand. You can re-programme these to suit your own requirements.

Noting: screen 1 of menu 1 will appear after start-up. The display will also revert to this screen if the meter is left untouched displaying another menu for a period of 2 minutes.

Top left of the display is the sequence of the screen within its menu and alternates with the alpha code that uniquely identifies the screen being viewed.

Scrolling through this menu using the blue scroll button, you will see that the first 6 screens show information on how to navigate the menus. The remaining screens show billing information on energy and demand.

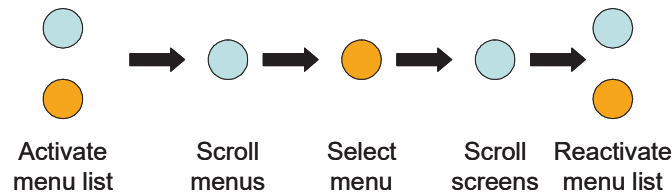

To navigate the menu use the following sequence of button presses.

Note the following:

- To use the orange reset button it must be turned so that the slot is vertical.
- To avoid scrolling when accessing the list of menus, hold down the reset button, immediately followed by the scroll button, and keep them both held down until the menu list appears.
- To scroll backwards in the menus hold down the reset button and quickly tap the scroll button.

Menu 1

GG	01 FOR GUIDANCE SeeDisplays 1to6	Information screen
GN	02 MENUS 1 TO 8 UserProgrammable	Information screen
GO	03 MENUS 9 TO 16 Reference menus	Information screen
GH	04 ToAccessMenus Hold→BothButtons	Information screen
GF	05 ReadRegisters PushScrollButton	Information screen
GP	06 To Exit Menu Hold→BothButtons	Information screen
GI	07 Following... Billing Readings	Information screen
GD	08 Read Running Energy & Demand	Information screen
JK	09 Date/Time Run 2005/11/29	Information screen
JQ	10 Energy 01 Run 0000053.13 kWh	Running energy & units
NV	11 MD01 Peak Run Highest Demand	Running MD function
NW	12 MD01 Reg Run 00000.0 VA	Running MD value & units
NX	13 MD01 Date Run yyyy/mm/dd hh:mm	Running MD date/time
GE	14 Read LastRset Energy & Demand	Information screen
JQ	15 Energy 01 S01 0000000.0 kWh	Stack 1 energy & units
NV	16 MD01 Peak S01 Highest Demand	Stack 1 MD function
NW	17 MD01 Reg S01 00000.0 VA	Stack 1 MD value & units
NX	18 MD01 Date S01 yyyy/mm/dd hh:mm	Stack 1 MD date/time
GQ	19 Following... TamperProofValue	Information screen
JS	20 Energy 02 Run 0000053.13 kWh	Running tamper-proof energy & units
NZ	21 MD02 Peak Run Highest Demand	

OA	22 MD02 Reg Run 00000.0 VA	Running tamper-proof MD value & units

Menu 2

GF	01 ReadRegisters PushScrollButton	Information screen
GP	02 To Exit Menu Hold→BothButtons	Information screen
GI	03 Following... Billing Readings	Information screen
GD	04 Read Running Energy & Demand	Information screen
JK	05 Date/Time Run 2005/11/29	Information screen
JQ	06 Energy 01 Run 0000053.13 kWh	Running energy & units
OD	07 MD03 Peak Run Highest Demand	Running MD function
OE	08 MD03 Reg Run 00000.0 VA	Running MD value & units
OF	09 MD03 Date Run yyyy/mm/dd hh:mm	Running MD date/time
GE	10 Read LastRset Energy & Demand	Information screen
JQ	11 Energy 01 S01 0000000.0 kWh	Stack 1 energy & units
OD	12 MD03 Peak S01 Highest Demand	Stack 1 MD function
OE	13 MD03 Reg S01 00000.0 VA	Stack 1 MD value & units
OF	14 MD03 Date S01 yyyy/mm/dd hh:mm	Stack 1 MD date/time
GQ	15 Following... TamperProofValue	Information screen
JS	16 Energy 02 Run 0000053.13 kWh	Running tamper-proof energy & units

Other Menus

The second pre-programmed menu shows billing information based on the kWh and thermal demand of the electrical system being monitored.

Menus 3 to 8 are empty, and can also be programmed to suit your needs.

Menus 9 to 16 containing the following information:

09	Reference: The first 40 energy registers for running and stack 1
10	Reference: The first 40 demand registers for running and stack 1...4
11	Reference: The Last demand
12	Reference: The Instantaneous V, A, W, VA, VAR, PF, phase angles, Quadrants etc.
13	Reference: Access to information on the module fitted in bay 1 in the meter.
14	Reference: Access to information on the module fitted in bay 2 in the meter.
15	Reference: Access to Info/set/State. E.G. date/time.
16	Factory reference only: Factory use during manufacture

Menu 15

GF	01 FOR GUIDANCE SeeDisplays 1to6	Information screen	CN	25 MER Lockout 00.00	Month-End reset will be blocked out for Hrs 00:00
GP	02 To Exit Menu Hold→BothButtons	Information screen	RN	26 CM Inputs SW State:000	Meter state can be live=ON or OFF, state depends on setting
FU	03 RTC Time 08:01:45	Meter's real time	RO	27 CM Inputs HW State:000	Monitors state if the meters inputs
FT	04 RTC Date 2005/12/05	Meter's real date	RP	28 CM Outputs State:000	Monitors state if the meters outputs
BT	05 CM Serial No 00000000	Meter serial number	DA	29 Tariff Name Two Part Tariff	Displays the current tariff being used by the meter
BA	06 Meter Model 34W230V50/60HZCT	What the meter can be set for	SS	30 TariffSummary Hol:N S:01D3S1t0	Indicates the current holiday, season, day & special day
TJ	07 Meter type 4W 400V 5A 50Hz	What the meter is set for	ST	31 Tariff R1-16 0000000000000000	From left to right; rate 1 to 16, will display 1 when active
TN	08 CT Pri/Sec 10000/5 Swt:5	Programmed current ratio & setting of CT 1/5A switch	SU	32 Tariff R17-32 0000000000000000	From L to R; rate 17 to 32, will display 1 when active
TK	09 CT Ratio 80.000	Calculated CT ratio Factor	WH	33 Prof 1 Detail SUM 30 1478	Channel 1 profile settings: Sum data every 30min; records
TO	10 VT Pri/Sec 132000/110	Programmed voltage ratio	WI	34 Prof 1 Value ----- Wh	Channel 1 profile present periods: Value & units
TL	11 VT Ratio 100.000	Calculated VT ratio Factor	WJ	35 Prof 2 Detail SUM 30 1478	Channel 2 profile settings: Sum data every 30min; records
BU	12 CM FW Version v.00.970 05/11/2	Meter's operating firmware version	WK	36 Prof 2 Value ----- Wh	Channel 2 profile present periods: Value & units
BC	13 MM FW Version V00.106	Meter's measurement firmware version	WL	37 Prof 3 Value Detail: Not used	Channel 3 profile settings: not set to record
AQ	14 ImportVersion 2005/12/05	Display text version used by meter	WM	38 Prof 3 Detail Value: Not used	Channel 3 profile not set
SD	15 CM UART S1 300 Rx 17815	Monitor optical head comms counts valid! & counts valid bytes	WN	39 Prof 4 Value Detail: Not used	Profile not set
SE	16 CM UART S2 RxErr 0	Count of attempts with incorrect comms settings	WO	40 Prof 4 Detail Value: Not used	Profile not set
SF	17 CM Mode-C Rx ID To: 0	Protocol status	WP	41 Prof 5 Value Detail: Not used	Profile not set
SG	18 CM CommsEvent Idle	What is being loaded into the meter	WQ	42 Prof 5 Detail Value: Not used	Profile not set
aj	19 EM1 Model E+EA-RS2324ZZZZ	Expansion Module, Model Information	WR	43 Prof 6 Value Detail: Not used	Profile not set
ai	20 EM1 Serial No 06130123	Expansion Module Serial number Information	WS	44 Prof 6 Detail Value: Not used	Profile not set
ad	21 EM1 FW Version V50.141 06/03/17	Expansion Module Firmware version Information	WT	45 Prof 7 Value Detail: Not used	Profile not set
BB	22 MM switches 5A tamper: 44	Monitors the CT 1/5A setting	WU	46 Prof 7 Detail Value: Not used	Profile not set
TM	23 IntMeterConst 100.000	Programmed meter internal constant (multiplier)	WV	47 Prof 8 Value Detail: Not used	Profile not set
JK	24 Date/Time Run 2005/11/29	Information screen	WW	48 Prof 8 Detail Value: Not used	Profile not set

Communicating with the Meter

This can be achieved in a number of ways. The Enermax+ has the standard optical communication window. The optical port is linked to a computer using an optical head that is supplied separately.

Using a suitable expansion module communication with a PC or PLC can be achieved via any of the following:

- RS 232 serial interface
- RS 485 serial interface
- GSM network
- PSTN line

Expansion Modules

A number of expansion modules are available to increase input/output lines, and to add communication facilities to the Enermax+. There are two bays for this. A expansion module is fitted by sliding it upwards into the bay, and pushing it firmly into place. To release it, press the spring catch on the body of the module while slide down and out of the bay.

Figure 5: Expansion Module in the Right Hand Socket

To wire up the module, expose the connectors by removing the cover on the lower part of its body.



Spring catch to remove module from meter

Figure 6: Expansion module with exposed connectors



Type Numbering

(*) indicates available options as at April 2006. Contact Strike Technologies for availability of other options.

Different versions of the meter are available. The numbering methodology is shown in Table 1. The numbering systems for the expansion modules, auxiliary equipment, and software are in tables 2, 3, and 4 respectively.

Table 1: Meter Numbering System

E	+	M	A	-	x	x	x	x	0	0	0
Future use											
Future use											
Future use											
3 = Calibrated for Class 0.5 - 3 wire only (*)											
4 = Calibrated for Class 0.5 - 4 wire only (*)											
7 = Calibrated for Class 0.5 - both 3 & 4 wire											
5 = CT Range 1(2)A or 5(10)A; DIP switch selectable; class 0.5 (*)											
7 = DIRECT Range 40(100)A; class 1.0											
9 = DIRECT Range 40(160)A; class 1.0											
6 = 3 x 63,5V L - N; 50/60Hz; 4 wire (*)											
1 = 2 x 110V L - L; 50/60Hz; 3 wire (*)											
4 = 3 x 230V L - N; 50/60Hz; 4 wire (*)											
5 = 2 x 380V to 550V L - L; 50/60Hz; 3 wire											
7 = 2/3 x 100V to 400V L - L; 57.5V to 230V L - N; 50/60Hz; 3 wire or 4 wire											
A = Version with M16 memory, 3 inputs & 3 outputs, Optical port, LCD (*)											
M = Meter											
E+ = Enermax plus equipment											

Table 2: Expansion Module Numbering System

E	+	E	A	-	x	x	x	x	x	x
GSM040 = GSM Cell modem plus RS485										
PSTN04 = PSTN card plus RS485										
RS2324 = RS232 plus RS485 (*)										
4N4T00 = 4 Input & 4 Outputs										
8IN000 = 8 Inputs										
8OUT00= 8 Outputs										
A = Version of module										
E = Expansion module										
E+ = Enermax plus equipment										

Table 3: Auxiliary Equipment Numbering System

E	+	A	A	-	x	x	x	x	-	x
AE02-5 = GSM/Cell antenna with 2.5mtr cable										
OPU1-8 = USB Optical head with 1.8 mtr cable (*)										
OPS1-8 = Serial Optical head with 1.8 mtr cable (*)										
S9F1-8 = 1.8mtr serial cable with 9DB FM (*)										
A = Version										
A = Auxiliary equipment										
E+ = Enermax plus equipment										

Table 4: Software Numbering System

E	+	S	W	-	A	0	0	-	x	x
01 = 1 licence (*)										
02 = 2 licences (*)										
00 = Options for SW - Basic SW (Dongle related) (*)										
01 = Options for SW - (Future modules) (Dongle related)										
02 = Options for SW - (Future modules) (Dongle related)										
A = User access level (Dongle password level) (*)										
SW = Computer Software										
E+ = Enermax plus equipment										

Electrical Parameters

METER ACCURACY			
IEC 62053	Active energy to IEC 62053-22	Class 0.5	
	Reactive energy to IEC 62053-23	Class 2.0	
LINE CURRENT & VOLTAGE (STATIC METER)			
LINE FREQUENCY			
Nominal Hertz	Program setting	50 or 60Hz	
	Tolerance	± 5%	
MEASUREMENT STARTING THRESHOLDS.			
IEC62053-22 (8.3.3)			
Phase	Phase voltage →	57V	110V
3	Starting voltage	45	45
3	CT starting current	0.1% I _N	
CT NOMINAL CURRENT IN			
IEC62053-22 (4.2)			
Dip select	I _N	I _{MAX}	Short circuit
1A	0....2A	200%	0.5s @ 20 x I _{MAX}
5A	0....10A	200%	0.5s @ 20 x I _{MAX}
Over range 20A For 60 min			
For 60 min			
LINE NOMINAL VOLTAGES			
Range →	100V....400V	57V....230V	Operating voltage range
4 wire	Line to line	Line to neutral	80%....115%
3 wire	---	Line to Common	80%....115%
BURDEN PER PHASE IN VOLTAGE CIRCUIT			
IEC 62053-61 (4.3-Multi-Function Meter)			
Test conditions		57Vac	110Vac
		230Vac	
Three phases connected, no modules fitted		<0.5W	<0.5W
		<1.0VA	<1.0
Three phases connected, two modules fitted		<1.0W	<1.0
		<2.0VA	<2.0
LINE BURDEN PER PHASE IN CURRENT CIRCUIT			
1A =	<0.05VA	2A =	<0.05VA
5A =	<0.1VA	10A =	<0.25VA
METER INSULATION WITHSTAND			
IEC62052-11 (7.4) & (7.3.1 to 7.3.3)			
METER IMPULSE VOLTAGE			
IEC62052-11 (7.3.2)			
Test with accordance specified in IEC 60060-1			
ELECTROSTATIC DISCHARGES			
IEC62052-11 (7.5.2) Contact discharged.		8kV	
ELECTROMAGNETIC RF FIELDS			
IEC62052-11 (7.5.3)			
80 MHz – 2 GHz tested to IEC 61000-4-3		10 and 30 V/m	
Radio Interference Suppression		IEC/CISPR 22	Class B
FAST TRANSIENT BURST TEST			
IEC62052-11 (7.5.4)		4kV	
SURGE IMMUNITY TEST			
IEC62052-11 (7.5.6)		4kV	
CLOCK			
IEC62054-21 (7.5.2.2 & 7.5.2.3)			
Accuracy		@ 25 Deg C: 0.5 s/day	
Synchronising		Crystal or line frequency	
BATTERY			
(Only for RTC during power down)			
RTC Back-Up	Meter powered-down period	Battery model	
Replaceable 3V Lithium	8 years	CR2032	
METER CONNECTIONS			
CLEARANCE AND CREEPAGE			
IEC62052-11 Class 2 (5.6)			
Voltage phase to earth derived from rated system		≥300V	
Rated impulse voltage		6000V	
PHASE TERMINAL – CONNECTIONS			
IEC62052-11 (5.4)			
Wire capacity		Cable 6 mm ²	
Terminal Quantity/Size		10 x 5 mm ID	
IEC62052-11 (5.9)			
Terminal Block Insulation Material		Flame retardant translucent Polycarbonate	
AUXILIARY TERMINALS			
TERMINAL BLOCKS			
Inputs	4 x terminals	3 + common, clamp 0.08....1.5mm ²	
Outputs	4 x terminals	3 + common, clamp 0.08....1.5mm ²	
Rated	Electrical	Current=	5A
	Impulse volts	Voltage=	300V
INPUTS			
Quantity	3	Digital	
Isolation	Optical	2kV Withstand	4kV Impulse
	Voltage	15....250VDC or 50....250VAC	
Operation	Current	Ac < 2 mA ohmic at 250V	
	Function	Program	
		For pulse and control inputs	

Outputs

Quantity	3	Solid state SPST relays
Isolation	Minimum	Input to output V _{I/O} 3750V _{RMS}
	Voltage	Dc 250 - Ac 250
Operation	Current	Maximum 200mA
	Form	Dead state: N/O
	Program	Standby state: N/O or N/C
		Outputs to be pulse and control

OPERATOR INTERFACES

MANUAL - BUTTONS

Reset	1 off	To Month-End reset: press & hold
Scroll	1 off	Scroll Displays or Menus
Security	Reset	Wire seal & programmable

LCD LIQUID CRYSTAL DISPLAY

Type 2 rows of 16 8 mm characters, dot matrix

LED'S

Faceplate	Calibration	IEC62052-11 (5.11)
	Indication	10 Imp/Wh & 10 Imp/varh: 2 x Red Line failure: 3 x Green: V1, V2, V3 Healthy: 1 x Green: behind comms lens

COMMUNICATIONS - OPTICAL PORT

Type	Serial	IEC 62056-21
		1 x Bidirectional, half duplex
Rx/Tx	Baud	Max bit rate: 115k
	Protocols	IEC 62056-21 Mode C

ENVIRONMENT

SHOCK AND VIBRATION

IEC62052-11 (5.2.2.2) & (5.2.2.3)

Shock= IEC 60068-2-27 Vibration= IEC 60068-2-6

HUMIDITY

IEC62052-11 (6.2 & 6.3.3)

None condensing up to 95%

TEMPERATURE

IEC62052-11 (6.1) & IEC 62053-22 (8.2)

Range→ Operation= -25 C....+55 C Storage= -25 C....+70 C

Coefficient Range → -20 C....+55 C

HOUSING

IEC62052-11 (5.9) IMPERMEABILITY IP51

IEC62052-11 (5.9) MATERIALS

INSTALLATION

DIMENSIONS

Width: 170 mm	Depth: 85 mm	Height: 270 mm
Mounting bracket	When reversed, add 22 mm on meter height	

MOUNTING

Fixing screws	location	Mounting
3 x ≤ 6mm diameter	Indoors	Flat surface

CABLES

Line voltage	CT current	Auxiliary
≤ 6mm ²	≤ 6mm ²	≤ 1.5mm ²

TERMINAL COVER

Fixing screws	Security	Breakouts
2	2 Wire seals	1 each side. 3 at bottom

SHIPPING

LOOSE METER

Mass 1.5 kg

METER + PACKAGING

Packaging box dimensions

Width 210 mm	Depth 140mm	Height 310mm
Mass	1.8 kg	

2006-01-12: All specifications subject to change without prior notice

Factory Default Settings

The factory default settings for the meter are listed below:

Inputs					
Input 1.	Block interval sync.				
Input 2.	Month-End reset.				
Input 3.	Select installation check menu.				
Outputs					
Output 1.	Block interval sync.				
Output 2.	Month-End reset.				
Output 3.	Voltage failure.				
CT switch					
	5 Amp				
	Register	Units	Rate	Function	Period
Maximum demand algorithm	Running	kVA	1	Block interval integration	30mins
kWh	Running	kW	1	Accumulated	24hrs
Month end reset	Manual, using the reset button				
System	3 or 4 wire, depending on meter model				

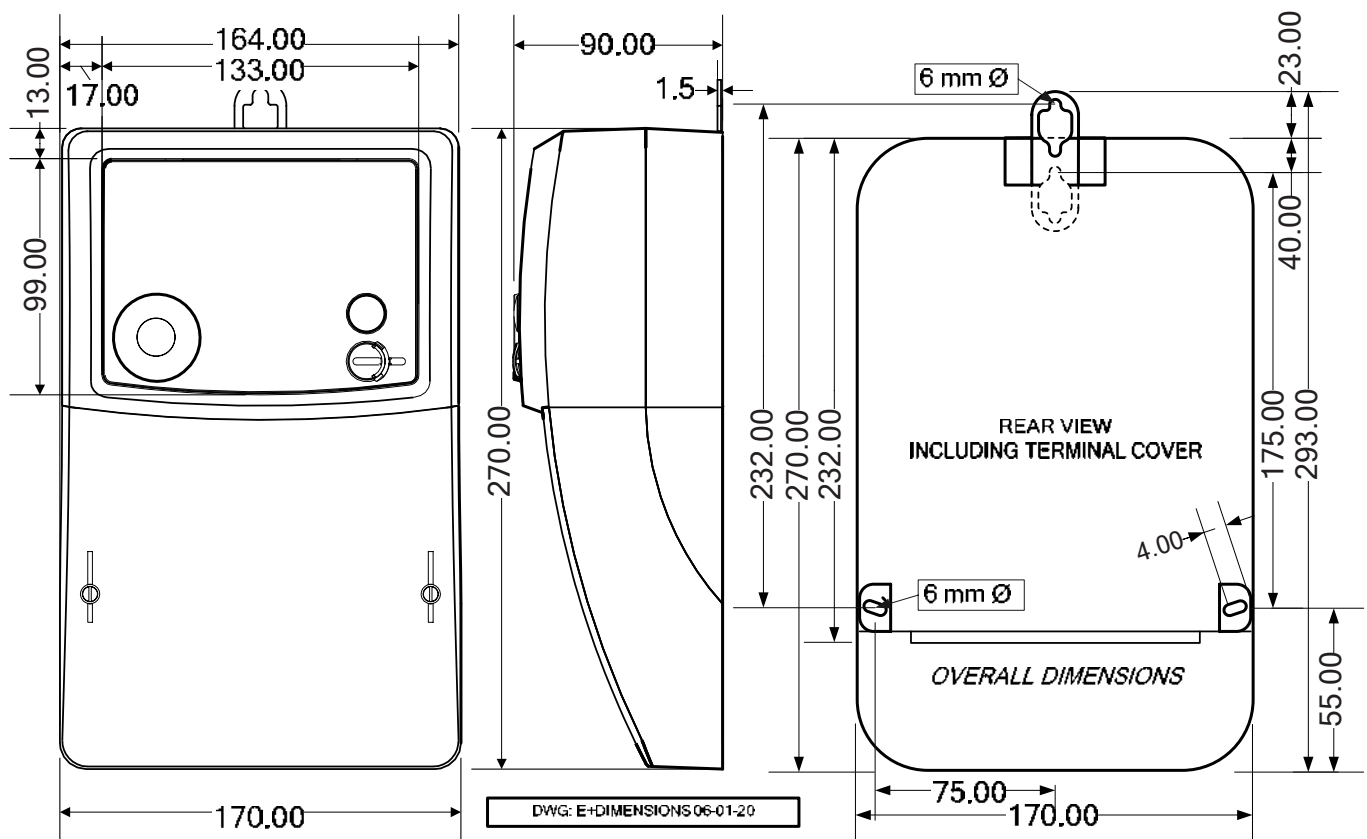
Figure 7: Dimensions

Typical Wiring Diagrams

Figure 8: 4 Wire Supply, direct voltage connection

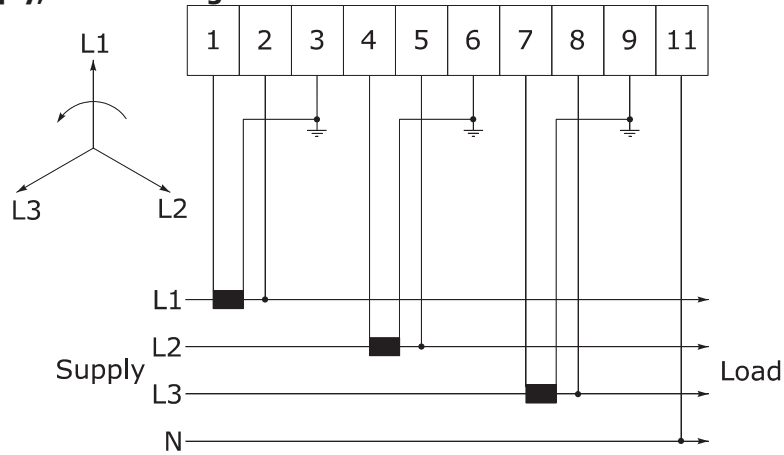

Figure 9: 4 Wire Supply, voltage connection via VTs

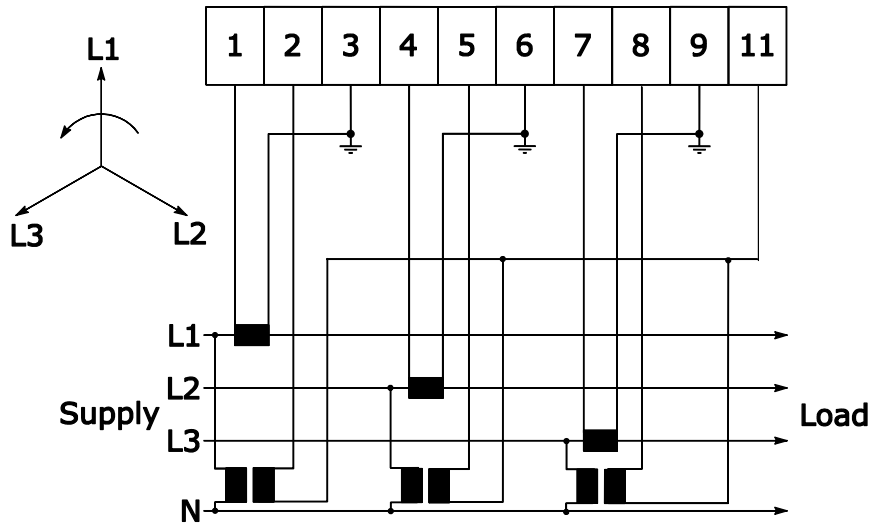

Figure 10: 3 Wire Supply, voltage connection via VTs

