

Industrial Isoloc®

Insulation Monitor & Earth Fault Limiter

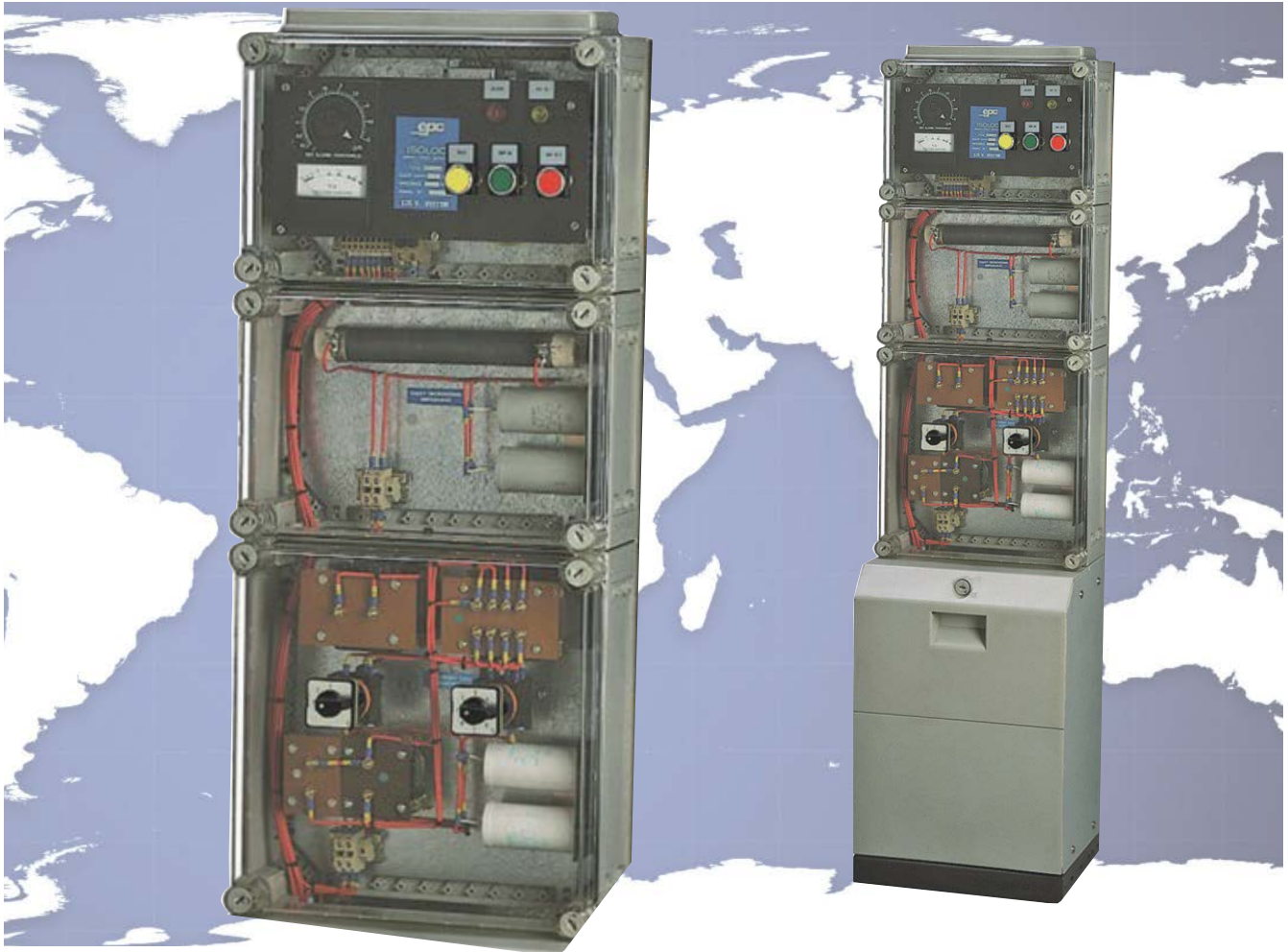

The system being offered provides a real saving in operational costs of continuous process plants. The damage at the point of a first earth fault is now completely eliminated. Earth bonding circuits are not stressed in anyway.

Key Features:

- . Manufactured and supported in South Africa
- . Used in continuous process plants
- . Allows process to continue while earth fault is found and eliminated
- . Wheatstone bridge system
- . Automatic supervision of the system insulation
- . Earth fault current limiter

Functions:

- . System Voltage up to 600V AC
- . Frequency: 50 and 60 Hz
- . Earthing impedance: 47,000 ohms inductive at 50 cycles
- . Adjustable alarm threshold: 100 to 5,000 ohms
- . Response time: 1 to 1.5 seconds

The ISOLOC® system compromises essentially three groups of equipment to serve the following functions:

- a) Earthing of the supply system
- b) Protection of the electrical system against over voltages, when Disneutor is incorporated
- c) Continuous monitoring of the earth insulation of the system

The characteristics of the available **OVER-VOLTAGE SHORT CIRCUIT SWITCHES** are detailed below:

DESCRIPTION	LDS 250	LDS 440	LDS 660
Rated Voltage	250V r.m.s	440V r.m.s	660V r.m.s
Spark-over Voltage 50Hz	Max. 750V r.m.s Min. 500V r.m.s	Max. 1,100V r.m.s Min. 700V r.m.s	Max. 1,400V r.m.s Min. 900V r.m.s
Impulse Spark-over Voltage 1.2/50	Max. 1,750V Peak	Max. 1,750V Peak	Max. 1,750V Peak
Residual Voltage for 5,000A peak	-	2,400V	3,000V
Residual Voltage for 2,500A peak	-	2,200V	2,750V
Residual Voltage for 1,400A peak	-	2,000V	2,500V
Residual Voltage for 400A peak	-	1,700V	2,100V
Rating Discharge Capacity	-	5,000 Amps peak	
Endurance	-	100 Impulses at 2,500 Amps peak 200 Impulses at 2,000 Amps peak	
Insulation Resistance before placing in Short Circuit	100 Megaohms	1,000 Megaohms	
Total Time of Permanent placing in Short Circuit	at 300 Amps - 20 milliseconds at 300 Amps - 20 milliseconds		
Permanent Current Withstands	Max. 1,000 Amps r.m.s		
Short Circuit Withstands	Max. 5kA for 1 minute Max. 10kA for 2 seconds Max. 20kA for 0.25 seconds		
Voltage Drop after Placing in Short Circuit	Less than 20 Volts		

It must be appreciated that the fault current to which the short-circuiting switch is subjected, will be a function of the transformer rating, as well as the fault capacity of the H.T. system. In certain circumstances an air cored FAULT LIMITING reactor will be supplied in series with the OVER-VOLTAGE SUPPRESSOR AND SHORT CIRCUITING SWITCH.

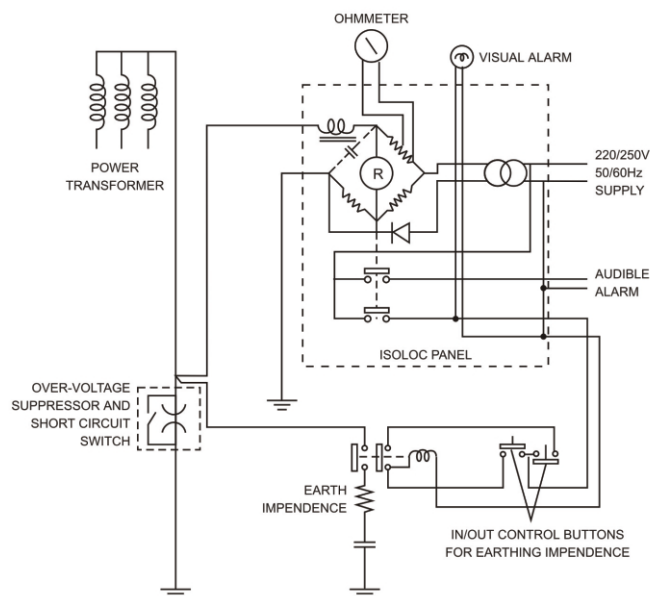

TECHNICAL DATA

Energising Voltage Source	: 220 Volts approx. 15%, 50-60 Cycles.
Bridge Voltage	: 15 Volts D.C. Stabilized.
Built-in Earthing Impedence	: 47,000 ohms inductive at 50 cycles.
Maximum Voltage of System that can be Monitored	: 600 Volts A.C.
Ohmmeter Range	: 0-50 kilo ohms / in ⁿ ity.
Adjustable Alarm Threshold	: 100 ohms to 5,000 ohms.
Response Time	: 1-1.5 seconds.
Alarm Contact Rating	: 2 N/O Contacts each 10 amps at 250 Volts A.C.
Alarm Voltage	: 220 Volts 50-60 Cycles.