

Capacitor & Filter Bank Protection Relay RLC04



Electrical Distributors

Operating & Instruction Manual

RLC 04





Electrical Distributors

Document History

Revision	Date	Description
RLC04-BB-1.0	2005-01-15	RLC04-B User Manual. Firmware Version 3.xx
RLC04-BB-1.0	2007-07-26	RLC04-B User Manual. Firmware Version 3.xx Changes: updated with new logo

About This Manual

These instructions cater for all possible contingencies likely to be met during installation, operation and maintenance of the equipment.

However, should particular issues arise that are not covered sufficiently, and further information is required, please contact the Technical Support Centre at Strike Technologies (Pty) Ltd.

Safety Symbol Legends



Warning

Draws attention to an operating procedure, practice, condition or statement, which, if not strictly observed, could result in injury or death.



Caution

Draws attention to an essential operating procedure, practice or statement, which, if not observed, could result in damage to, or destruction of, equipment.



Note

Draws attention to an essential operating or maintenance procedure, or statement that must be observed.

RLC04-B Capacitor and Filter Bank Protection Relay

Complete Operating and Instruction Manual





Electrical Distributors



Electrical Distributors

Table of Contents

INTRODUCTION.....	9
PRODUCT OVERVIEW	10
Application	10
Main Product Features	10
Protection Functions	10
Test functions.....	10
Inputs	10
Outputs.....	11
Enclosure	11
User Interface	11
Data Communications.....	11
Application Software	11
Product Evolution Information	11
FUNCTIONAL DESCRIPTION	12
Protection Functions	12
Normal Mode	12
Repetitive Peak Overvoltage Protection	12
Programmable $v_{c>reset}$ Time	13
Thermal Overcurrent Protection.....	14
Fundamental Frequency Star Point Unbalance Protection.....	15
Fundamental Frequency Line Current Unbalance Protection.....	15
Fundamental Frequency Earth Fault Protection	16
Fundamental Frequency Overvoltage and Overcurrent Protection	16
RMS Overcurrent Protection	16
Fundamental Frequency Undercurrent Protection.....	16
Breaker Fail Protection.....	17
Capacitor Bank Re-switching Protection.....	17
Event Trip	17
H-Bridge Mode	18
Fundamental Frequency H-Bridge Unbalance Protection	18
Inputs and Outputs	19
Element Inputs	19
Output Relays	19
Relays K1 to K5.....	19
Relay K6 Self-supervisory Output.....	19
Contact Forms.....	19
Relay Checksum	20
Digital Input	20
Breaker-Bon	20
Event Tripping	20
Remote Reset	20
Other Facilities.....	20
Password Protection	20
Test Facilities	20
PC Based Software Package.....	21
Modbus Protocol.....	21



Electrical Distributors

Enclosure and Draw-out Unit.....	22
Terminals	22
User Interface	22
Five button keypad.....	23
Status LEDs	23
LCD Display	23
LCD Display	24
Serial Data Port.....	24
Auxiliary Power Supply.....	24
INSTALLATION AND COMMISSIONING.....	25
Unpacking, Storage and Handling.....	25
Enclosure and Draw-Out Unit.....	25
Configuring the Hardware Prior to Installation.....	26
Output relay contact form.....	26
Mounting.....	26
Wiring.....	27
Auxiliary power supply	27
Current transformer circuits	27
Output Relay Circuits	27
Digital Input	28
Serial Communication Port	28
Earth Connection	28
Noise Isolation	28
1 st Level Menus	30
2 nd Level Menus.....	31
Changing or Selecting Parameters.....	31
Some Exceptions	31
Some Exceptions	32
Scrolling	32
The Exit Process.....	32
PROGRAMMING THE RLC04-B.....	33
Configuring the Hardware.....	33
Setting the Password.....	33
Serial Port Options	33
Serial Port Options	34
Parameter Setup - Normal Mode	35
Set Element 1, 2, 3 Variables	35
Set Element 4 Variables	36
Set Element 5 Variables	36
Set Other Functions	36
Compensate for Star Unbalance	37
Clear Trip History	37
Output Relay Setup – Normal Mode	37
Parameter Setup – H-Bridge Mode	38
Set Element 2, 3, 4 Variables	38
Set Other Functions	39
Compensation for xIub.....	39
Clear Trip History	39
Output Relay Set-up - H-Bridge Mode	40



Electrical Distributors

OPERATING THROUGH RLC04-B	41
Healthy Condition	41
The LED Indicators	41
The Running Displays	41
Normal Mode Displays	42
H-Bridge Displays	42
Default Display	43
Fault Condition	43
The LED Indicators	43
The Running Display	43
Post-trip Fault Annunciation Displays	43
Typical Post-Trip Annunciation Displays	44
Information Retrieval	44
Trip History List	44
Status Information	45
Relay configured in Normal Mode	46
Relay configured in H-Bridge Mode:	46
Clearing the Counters	46
TESTING AND TROUBLESHOOTING	48
Automatic Self-testing	48
User-performed Diagnostic Tests	48
Injection Testing	49
Trouble Shooting	50
APPENDIX 1	51
Table 1 - Step-By-Step Installation Instructions	51
Table 3: Nomenclature & Definitions for H-Bridge Mode	54
Table 4: General Characteristics	55
Table 5: Technical Specifications	56
Table 6: Settable Parameters and Ranges – Normal Mode	57
Table 7 – Settable Parameters and Ranges – H-Bridge Mode	58
APPENDIX 2	59
Example 1: Calculation of Checksums for Output Relays 1 To 5	59
Typical Examples of Output Relay Settings and Resulting Checksums	59
One of 5 Output Relays in Normal Mode Operation	59
One of 5 Output Relays in H-Bridge Mode	59
Example 2: RLC04-B Setting Calculations	60
20 Mvar harmonic filter with a double star capacitor bank	60
Settings	61
Notes on Settings	61
Example 3: Calculation of the Reactor Heating and Cooling Time Constant (τ)	64
Appendix 3	65
Figure 1: Relay Case and Panel Cut-out Dimensions	65
Figure 3: Repetitive Peak Overvoltage vs. Trip Time Curves	66
Figure 3: Repetitive Peak Overvoltage vs. Trip Time Curves	67
Figure 4: Thermal Trip Time Curves	67
Figure 4: Thermal Trip Time Curves	68
Figure 5: Typical Application Examples	69
Figure 6: Typical Wiring Diagram For A Double Star Capacitor / Filter Bank	69



Electrical Distributors

Figure 6: Typical Wiring Diagram For A Double Star Capacitor / Filter Bank	70
Figure 7: Element Failure in a Double Star Connected Capacitor Bank.....	71
Figure 8: Typical Wiring Diagram for an H-Bridge Capacitor / Filter Bank.....	72
Figure 9: Element Failure in an H-Bridge Connected Capacitor Bank.....	72
Figure 9: Element Failure in an H-Bridge Connected Capacitor Bank.....	73
Figure 10: Output Relay 1 to 5 Configuration.....	74



Electrical Distributors

Introduction

The RLC04-B is a capacitor and filter bank protection relay. It has been built on the foundation of years of continued development through previous successful models. The RLC04-B has quality embedded into every stage of its design and it has been manufactured to the strictest quality standards. Combining state of the art hardware technology and software techniques it provides the most convenient functionality in its sphere.

This manual contains an overview, functional description, and specification of the RLC04-B, as well as detailed instructions on installation, commissioning, setting up, operation, and maintenance.

Whilst it provides a wealth of information, this manual does not replace the need for anyone installing, operating, or maintaining the equipment to be suitably qualified and/or trained. Such a person should have a prior knowledge of power system protection, power system measurements, and power system safety procedures. Before installing, setting up or operating the RLC04-B, the user should study the applicable sections of this manual, taking particular note of WARNINGS, CAUTIONS and NOTES included for the safety and protection of both personnel and equipment.

Before attempting to troubleshoot the equipment, the user should thoroughly understand the entire manual. For troubleshooting and commissioning the following equipment is required:

- Digital multimeter with clip-on current tong for measuring 1A or 5A current transformer secondary.
- Preferably a three-phase, alternatively a single-phase, primary or secondary injection test set, which is included in the product range offered by Strike Technologies.

Due to the nature of the RLC04-B relay, it is not recommended that the user should attempt repairs other than the removal and replacement of the draw-out unit that houses all electrical and electronic parts. Any faulty RLC04-Bs should be returned to Strike Technologies (Pty) Ltd. for testing, and if necessary, for repair or replacement of faulty parts, re-calibration and re-testing.

Thank you for purchasing the RLC04-B protection relay, please contact Strike Technologies (Pty) Ltd for further details should they not be covered within this manual



Electrical Distributors

Product Overview

Application

The RLC04-B Protection Relay provides comprehensive protection for the capacitive, inductive and resistive elements of three phase medium voltage and high voltage shunt capacitor banks and harmonic filter circuits. The capacitor banks consist of several individual capacitors in a series – parallel arrangement. Each individual capacitor within a bank may be internally fused, externally fused or unfused. A number of banks are constructed as a single star, double star, delta or H-bridge configuration.

In normal conditions these banks are balanced, i.e. each leg draws the same current as near as practically possible. Should one or more of the capacitor elements fail, the system will become unbalanced and the RLC04-B will sense this and can be used to trip any necessary circuit breakers.

The RLC04-B has additional protection features such as for fundamental and harmonic overcurrent and overvoltage, as well as over temperature conditions and residual earth currents.

Due to its accuracy and short response times, the relay provides the optimum protection for a system. By only operating when absolutely necessary it prevents unnecessary trip outs thereby preventing unnecessary financial losses and other detrimental consequences. In addition, after a system fault or equipment failure, the RLC Protection Relay trips the associated circuit breaker timorously, to ensure maximum personnel safety, and to minimize further equipment and other consequential damage.

Main Product Features

Protection Functions

- Repetitive peak overvoltage
- Thermal overcurrent
- Fundamental frequency overvoltage and overcurrent
- RMS overcurrent
- Fundamental frequency star point unbalance
- Fundamental frequency line current unbalance
- Fundamental frequency H-bridge configuration unbalance
- Fundamental earth fault current
- Fundamental frequency undercurrent
- Breaker Fail detection
- Capacitor bank re-switching
- Event tripping

Test functions

Both on-line and user activated hardware diagnostic testing

Inputs

- 4 Dual Current Measuring Elements - Individually programmable for either 1A or 5A
- Optically isolated digital blocking input - User configurable for active low/active high
- Wide range AC/DC Auxiliary Power Supply (30 – 250V AC/DC)



Electrical Distributors

Outputs

5 Trip/Alarm output relays (K1 to K5), programmable with regard to energisation and latching functionality, hardware configurable NO/NC contact form

1 Dedicated self-supervisory output relay (K6), hardware configurable NO/NC contact form

Enclosure

Flush mount and 19" rack compatible

Draw-out facility, with automatic shorting of CT input connections

User Interface

3 LED Status Indication: Healthy (Green); Alarm/Start (Yellow); Trip (Red)

Alpha-numeric, backlit, Liquid Crystal Display (2 lines x 16 characters)

Menu driven user interface with 5 button interactive keypad

Data Communications

Two serial interfaces for programming and interrogation

Remote communication by means of RS232 or RS485, either via a dedicated line or via a modem (PSTN or GSM).

Both Strike protocol and Modbus RTU protocol co-reside in the product

Application Software

Windows 95/98/2000/NT/XP Software Package, for local programming/data uploading, as well as remote communication via modem

Product Evolution Information

Released in early 2005, the RLC04-B replaces the earlier RLC Version 3 model. Although similar in overall functionality, there have been many major upgrades in hardware, specification, and operation to its predecessor. "One relay fits all". All of the features that were previously optional when ordering the relay, are now programmable via the set up menu. This means that there is only one version of this relay, which helps reduce your stockholding and offers the greatest flexibility should operating conditions change. The new application software addresses these new features.

The following are just some of the features that are new in the RLC04-B:

- Normal Mode or H-Bridge Mode is now programmable in the same unit
- 50Hz or 60Hz operation is now programmable
- 1A/5A CT selection is now programmable – no external wiring to change
- A second serial port (RS232) has been positioned on the front panel for ease of connection to a lap-top computer. This port is used for any communication with the unit, including Strike PC software or MODBUS, and in particular for firmware upgrades.
- The serial port on the rear of the unit is now RS232/RS485 programmable. This port can be used for Strike PC software or MODBUS.
- Both serial ports are separately programmable to baud rates of 2400 to 115200
- Greater accuracy of time and current measurements
- Much improved response time
- Time stamping of the trip history records and certain other status registers
- The digital input can be configured as one of three alternative functions; Breaker on sensing, an event input, or for remote reset
- Lost password recovery procedure avoids having to return the product to the factory for re-initialisation.



Electrical Distributors

Functional Description

Protection Functions

Shunt capacitor and filter banks are used in medium and high voltage systems to provide power factor correction and reduce unwanted harmonics being fed back onto the mains grid. Any one of a number of standard circuitries can be used to provide capacitor or filter bank protection in a system. With its 4 Analogue Input Elements, 1 Digital Input, 5 output relays for system protection, and 1 output relay for self-supervision purposes, the RLC04-B can be programmed to handle any of these configurations.

The measured currents themselves, or several other values calculated from them, are compared to threshold values entered into the RLC04-B by the user. These can be alarm, low-set, or high-set thresholds, although not all threshold types are relevant to all functions. If a threshold value is exceeded, a start signal is immediately generated, which in itself can be used to activate one or more output relays, and a timer linked to that function starts running. Should the threshold remain exceeded for a specified time-out period, normally also entered by the user, an alarm or trip signal will be generated. The RLC04-B can be programmed to respond by switching any permutation of the output relays for each particular signal/threshold combination.

The relay's functionality and programmable options adapt according to the type of circuitry being protected. We therefore need to describe the two major circuit groups separately in the following sections.

Normal Mode

This mode is applicable to star, delta, and double star circuits.

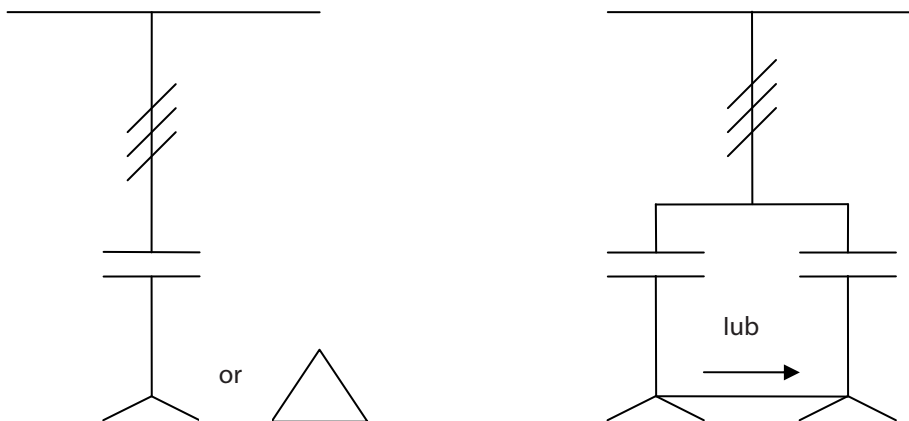

Repetitive Peak Over voltage Protection

The dielectric of a capacitor bank is stressed by the repetitive peak voltage applied to it. According to recognized standards, a capacitor bank (and its individual elements) must be able to withstand an RMS sinusoidal voltage of 110% of its rated voltage at rated frequency for extended periods.

Thus a capacitor can withstand a repetitive peak voltage of $1.1 \cdot \sqrt{2} \cdot U_N$ for extended periods.

A capacitor can withstand even higher voltages for short periods. The Temporary Overvoltage Withstand curve defines the time the capacitor can survive such overvoltage before failure (Refer to Figure 3 in Appendix 3). This curve has been derived from the relevant ANSI and IEC recommendations.

In operation, the RLC04-B measures the fundamental frequency current flowing in the capacitor banks in each of the three phases, as well as any super-imposed harmonics (up to the 50th). These current measurements are then integrated to provide the repetitive peak voltages VC for each capacitor bank. This value VC is then compared to three adjustable thresholds:



Electrical Distributors

The alarm threshold $VC>al/vcr$, with an associated adjustable definite time-out period, $VC>al:xt$; if VC exceeds the threshold for the time set, the alarm signal $VC>alarm$ is generated.

The low-set threshold, $VC>/vcr$. For voltages above this threshold, a starter signal, $vc>start$ starts a trip timer. The ANSI inverse time curve defines the time before the low-set trip signal, $vc>trip$, is generated, and providing that the voltage still exceeds the threshold.

The high-set threshold, $vc>>/vcr$, with an associated adjustable definite time-out period $vc>>:xt$, is available to provide a high-set trip output $vc>>trip$, if the associated threshold is exceeded for the definite time set.

Programmable $vc>reset$ Time

In the second situation above, when the low-set threshold $vc>/vcr$ is exceeded, the trip timer is started. If the overvoltage recovers to below the set threshold before the trip timer times out, no trip occurs but the trip timer is not cleared, but rather is held for a programmable reset time, $vc>reset$, before resetting. Should the threshold be exceeded again before expiry of this reset time, the trip timer starts incrementing from its previous value. This means that such a condition can still result in a trip because of the prior accumulated count value in the trip timer. This helps take care of the “memory effect” of capacitors. If this feature is not required, $vc>reset$ can be set to zero.

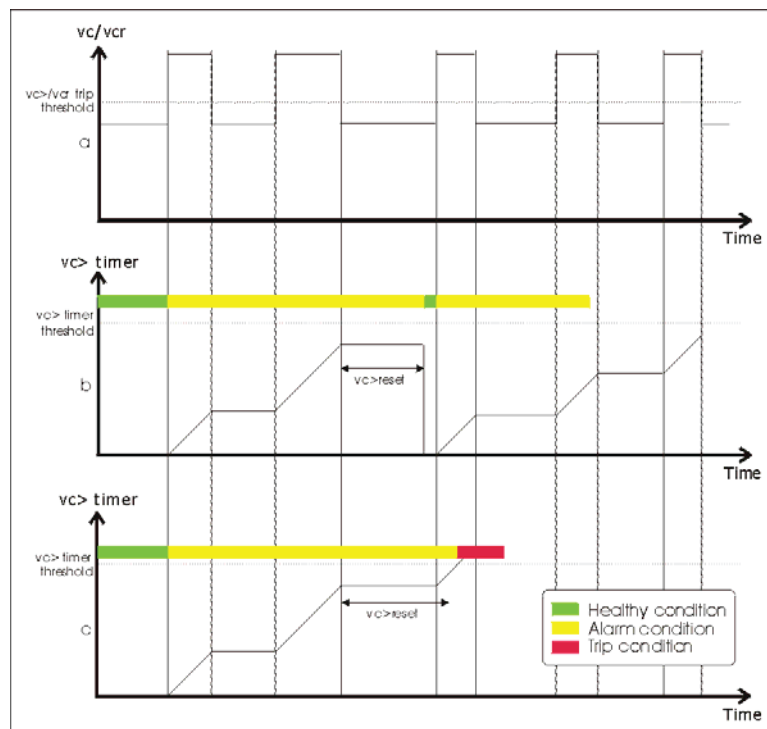

The graphs show a sequence of intermittent overvoltages in a monitored circuit, with two different consequences for the relay condition dependent upon the $vc>reset$ value chosen:

The vc/vcr voltage ratio, occasionally exceeding the low-set trip threshold value.

The accumulating trip timer value with a shorter $vc>reset$ value, allowing an intermediate trip timer reset.

The accumulating timer value with a longer $vc>reset$ value, thus allowing no intermediate reset of the trip timer, and eventually creating a trip condition.



Electrical Distributors

Thermal Overcurrent Protection

All of the components making up a capacitor bank / harmonic filter circuit are stressed thermally by the current I_{rms} which flows through them. This applies to all of the elements such as circuit breaker, feed cable, damping or filter reactors, and filter resistors, as well as the capacitors. I_{rms} comprises both the fundamental and harmonic components. The RLC04-B protects the banks against such excessive temperature rise which would otherwise lead to damage of the components and cause a breakdown.

According to recognized standards, a capacitor bank, and the capacitor units making up the bank, must be rated to withstand a continuous current of 130% of the rated current.

For each phase, the RLC04-B protects a capacitor bank / harmonic filter circuit from excessive current stressing, by modeling the thermal response of the circuit to the total heating current, I_{rms} .

After a system has been running for a short while, it will heat up to a particular temperature, caused by I_{rms} . At any point before that steady state condition is reached, the lower temperature of the system so far attained could be said to be caused by a lower effective thermal current, represented as I_{th} . When the system eventually reaches the steady state condition, I_{th} equals I_{rms} . The time constant which determines how quickly this occurs depends upon the system.

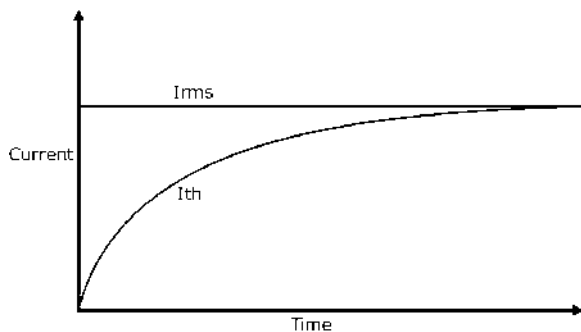

I_{rms} is the actual instantaneous measured current, while I_{th} is the effective heating current which lags I_{rms} depending upon τ .

Using advanced digital signal processing techniques I_{rms} is continuously calculated from the measured line currents, both fundamental and harmonics (up to the 50th). A second order thermal model with an adjustable heating / cooling time constant τ , is then used to continuously calculate the thermal current response, I_{th} , to the heating current, I_{rms} . I_{th} is continuously compared to the adjustable low-set and high-set thresholds, $I_{th>}$ and $I_{th>>}$, each linked to their corresponding trip signals $I_{th>trip}$, and $I_{th>>trip}$, which are generated, if the associated thresholds are exceeded for the definite times set.

However, it is possible to set the low-set time-out period $I_{th>xt}$ to "Alarm". The low-set function then acts purely as an alarm, and only the $I_{th>start}$ signal is generated, without a subsequent $I_{th>trip}$ signal.

The trip times can be evaluated using the following formula:

$$t/\tau = -\ln \left(\frac{(I/I_{th>})^2 - 1}{(I/I_{th>})^2 - (I_0/I_{th>})^2} \right)$$

where $I/I_{th>} =$ overload current / thermal trip threshold current

and $I_0/I_{th>} =$ pre-load current / thermal trip threshold current



Electrical Distributors

Fundamental Frequency Star Point Unbalance Protection

In a double star connected capacitor bank, the failure of internal capacitor elements, and the subsequent blowing of internal capacitor element fuses or external capacitor unit fuses, is detected by sensitive monitoring of the unbalance current flowing between the two star points.

Even though efforts may be taken to balance a double star connected capacitor bank, by optimum selection and positioning of the capacitor units making up the bank, the tolerance in capacitance is such that a “natural” fundamental frequency star point unbalance current flows under normal conditions.

The RLC04-B measures the star point unbalance current and calculates the fundamental frequency component, I_{lub} . This can then be compensated, in magnitude and phase angle, to zero, to enable further changes, in both magnitude and phase angle, ΔI_{lub} , from the initial uncompensated value, to be determined. The magnitude of ΔI_{lub} is a measure of the change in capacitance in any leg of a double star capacitor bank arrangement, whereas the phase angle of ΔI_{lub} indicates the leg in which the change in capacitance has occurred.

The magnitude of $(\Delta)I_{lub}$ is continuously compared to an adjustable alarm threshold, I_{lub_al} , and trip thresholds, $I_{lub>}$ and $I_{lub>>}$ each with associated adjustable definite time-out periods, $I_{lub_al:xt}$, $I_{lub>:xt}$ and $I_{lub>>:xt}$ respectively. Where $(\Delta)I_{lub}$ exceeds I_{lub_al} for the definite time set, an alarm signal, I_{lub_alarm} , is generated. In addition, a starter signal $I_{lub>start}$ as well as low-set and high-set trip signals, $I_{lub>trip}$, and $I_{lub>>trip}$, are generated, if the associated thresholds are exceeded for the definite times set.



Note

If the natural unbalance has been compensated and the fundamental current in the reference phase (Element1) drops below 10% of the nominal current, the star point unbalance protection functions are suspended, and the compensation vectors are ignored.

If the natural unbalance is not compensated and the fundamental current in the reference phase drops below 10% of the nominal current, the star point unbalance protection function operates only on the amplitude of the measured unbalance current – the phase angle will not be taken into consideration.

The advantage of star point unbalance protection is that, unlike line current unbalance, the magnitude and phase angle of $(\Delta)I_{lub}$ is not influenced by any phase imbalance in the supply voltage. Therefore the sensitivity can be much higher than line current unbalance measurement, without spurious tripping caused by unbalanced supply voltages. This sensitivity is often essential for adequate protection of larger capacitor banks with both internal/external and unfused capacitor units.

In addition, the star point unbalance protection function indicates the leg of the double star bank in which the change in capacitance has occurred. This is particularly convenient for larger capacitor banks with internally fused or unfused capacitor arrangements, to speed up the identification of faulty capacitor units. Refer to Figure 7 in Appendix 3 for more details on this.

Fundamental Frequency Line Current Unbalance Protection

The monitoring of fundamental frequency line current unbalance provides a means of detecting changes in impedance resulting from failures and faults within the capacitive, inductive and resistive elements of a capacitor bank / harmonic filter circuit. These faults or failures invariably result in an unbalance in the fundamental frequency component of the line currents.

The RLC04-B calculates the fundamental frequency line unbalance, I_{lub} , from the fundamental frequency components of the three phase line currents. I_{lub} is continuously compared with two adjustable thresholds, $I_{lub>}$ and $I_{lub>>}$, each with an associated adjustable definite timer, $I_{lub>:xt}$ and $I_{lub>>:xt}$.



Electrical Distributors

For I_{ub} greater than $I_{ub>}$, a starter signal, $I_{ub>start}$, is generated. In addition, low-set and high-set trip signals, $I_{ub>trip}$ and $I_{ub>>trip}$, are generated if the associated thresholds are exceeded for the definite times set.

The sensitivity of line current unbalance protection is limited by the effect of supply voltage unbalance on the line currents. Nevertheless, line current unbalance protection is useful as back-up protection to star point unbalance protection, as well as for early detection of filter resistor and reactor faults, and for early detection of capacitor element failures in smaller capacitor banks, in single star or delta connected arrangements, where star point unbalance protection is not provided.

Fundamental Frequency Earth Fault Protection

The RLC04-B calculates the fundamental frequency residual or earth fault current, I_o , as the magnitude of the vector sum of the three fundamental frequency components of the three phase line currents. I_o is compared with two adjustable thresholds, $I_o>$ and $I_o>>$, each with an associated adjustable definite time-out period, $I_o>:xt$ and $I_o>>:xt$. For I_o greater than $I_o>$, a starter signal, $I_o>start$, is generated.

In addition, low-set and high-set trip signals, $I_o>trip$ and $I_o>>trip$, are generated if the associated thresholds are exceeded for the definite times set.

Fundamental Frequency Overvoltage and Overcurrent Protection

In the absence of any equipment failures or system faults, the fundamental frequency line currents flowing in a shunt connected capacitor bank / harmonic filter circuit are proportional to the fundamental frequency supply voltage.

For each phase, the RLC04-B calculates the fundamental frequency component, I_1 , of the line current. I_1 is continuously compared with two adjustable thresholds, $I_1>$ and $I_1>>$, each with an associated adjustable definite time-out period, $I_1>:xt$ and $I_1>>:xt$. For I_1 greater than $I_1>$, a starter signal, $I_1>start$, is generated. In addition, low-set and high-set trip signals, $I_1>trip$ and $I_1>>trip$, are generated if the associated thresholds are exceeded for the definite times set.

The low-set fundamental frequency overcurrent threshold is typically set a little higher than the current that would flow at the maximum system voltage, e.g. at say 107,5% of nominal, with a fairly long definite time setting of, say 300 seconds. This protects the capacitor bank/harmonic filter circuit from an abnormally high supply voltage, in excess of the declared maximum system voltage.

A fundamental frequency line current much higher than that which would normally flow at the maximum system voltage, indicates a catastrophic phase-to-phase, three phase or phase-to-earth fault, or major equipment failure, requiring immediate disconnection of the capacitor bank / harmonic filter circuit. Therefore the high-set fundamental frequency overcurrent threshold is typically set at, say 150% of nominal, with a much shorter time delay setting.

RMS Overcurrent Protection

For each phase, the RLC04-B calculates the RMS current, I_{rms} , comprising both the fundamental and harmonic components of the line current. I_{rms} is continuously compared with two adjustable thresholds, $I_{rms>}$ and $I_{rms>>}$, each with an associated adjustable definite time-out period, $I_{rms>:xt}$ and $I_{rms>>:xt}$.

For I_{rms} greater than $I_{rms>}$, a starter signal, $I_{rms>start}$, is generated. In addition, low-set and high-set trip signals, $I_{rms>trip}$ and $I_{rms>>trip}$, are generated if the associated thresholds are exceeded for the definite times set.

Fundamental Frequency Undercurrent Protection

If the mains power supply should fail, while the capacitor bank / harmonic filter circuit breaker is on (Digital input "active" and configured as "Breaker on"), then it is prudent to trip the capacitor bank / filter circuit breaker. After restoration of the mains supply, the bank can then be re-energized under controlled conditions, after the system



Electrical Distributors

load has been re-established. In certain cases this can help to avoid over correction and excessive voltage rise, due to load rejection during a mains power dip.

For each phase, the RLC04-B calculates I_1 , the fundamental frequency component of the line current. I_1 is continuously compared with an adjustable undercurrent threshold, $I_{1<}$, and associated adjustable definite time-out period, $I_{1<:xt}$. With the capacitor bank / harmonic filter circuit breaker on, if the mains power supply fails, as indicated by a drop in I_1 below $I_{1<}$ for longer than the definite time set, then the undercurrent trip signal, $I_{1<:trip}$, is generated.

Breaker Fail Protection

Bfail1

Any one of the following conditions can be selected to signal successful breaker operation:

[1]	Ifund<10% of In	a drop in the fundamental currents below 10%
[2]	Dig-Input	a change of the digital input from active to inactive
[3]	Ifund OR Input	logical OR combination of [1] and [2]
[4]	Ifund AND Input	logical AND combination of [1] and [2]

If the selected condition is not fulfilled within a programmable time-out period, $B_{fail1:xt}$, after the RLC04-B issues a trip output, a Bfail1 signal is generated which can be allocated to one or more of the output relays. For selections which involve the digital input, the input function must be set to "Breaker-Bon" or else the release function will be default to $I_{fund<10\%I_n}$.

Bfail2

In addition to the above, if I_1 remains above 10% of rated I_n , for longer than the adjustable definite time-out period, $B_{fail2:xt}$, after the breaker switches off (digital input set to "Breaker- Bon" - indicates the breaker open/close status), then this indicates a major failure of the capacitor bank / harmonic filter circuit breaker, and the breaker fail signal, Bfail2, is generated.

Both signals can be used to trip an upstream breaker.

Capacitor Bank Re-switching Protection

When a capacitor bank / harmonic filter circuit breaker switches off for any reason, it should not be re-energized until the capacitor bank has discharged. This will prevent severe and stressful voltage and current transients due to the application of mains supply voltage onto a charged capacitor bank.

The RLC04-B provides the necessary logic, and a breaker enable output signal, Bena, to inhibit the re-energization of the circuit breaker, for an adjustable definite time, $B_{ena:xt}$, since de-energization.

Bena can be triggered by a choice of the following:

[1]	Ifund<10% of In	a drop in the fundamental currents below 10%
[2]	Dig-Input	a change of the digital input from active to inactive
[3]	Ifund OR Input	logical OR combination of [1] and [2]
[4]	Ifund AND Input	logical AND combination of [1] and [2]

Bena can be allocated to one or more of the output relays.

This allows the user to configure the RLC04-B in the most suitable way for the application.

Event Trip

The RLC04-B offers the possibility to trip the relay from an external signal via its digital input. A precondition is that the digital input must be configured as an Event trip input. If the digital input changes its state from inactive to active for the definite time-out period $Event:xt$, the generated function, $Event_trip$, can be used to operate any of the output relay(s).



Electrical Distributors

H-Bridge Mode

Fundamental Frequency H-Bridge Unbalance Protection

The RLC04-B offers this mode to provide sensitive unbalance protection independently for each phase of an H-Bridge configured capacitor bank.

Even though efforts may be taken to balance an H-bridge capacitor bank by optimum selection and positioning of the capacitor units, the manufacturing tolerance in capacitors is such that a “natural” fundamental frequency unbalance current flows under normal conditions.

The unbalance currents are measured in each phase of an H-bridge configured capacitor bank. Out of these values the fundamental frequency components a_{lub} , b_{lub} and c_{lub} , are calculated. These can then be compensated in amplitude and phase angle to zero, to enable further changes in both magnitude and phase angle, Δa_{lub} , Δb_{lub} and Δc_{lub} , from the initial uncompensated value, to be determined.

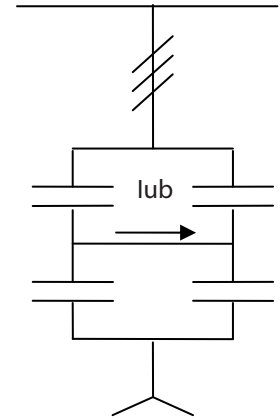

The magnitude of Δa_{lub} , Δb_{lub} or Δc_{lub} is a measure for the change in capacitance, while the phase angle indicates the leg in which the change in capacitance has occurred.

The magnitudes of $(\Delta)a_{lub}/c_{lub}$ are continuously compared to adjustable alarm thresholds a_{lub}/c_{lub_al} , low set trip thresholds $a_{lub}/c_{lub>}$, and the high set trip thresholds $a_{lub}/c_{lub>>}$. Each of these thresholds is linked to an associated adjustable definite time-out period, $a_{lub}/c_{lub_al:xt}$, $a_{lub}/c_{lub>:xt}$, and $a_{lub}/c_{lub>>:xt}$ respectively. For $(\Delta)a_{lub}/c_{lub}$ greater than a_{lub}/c_{lub_al} for the definite time set, an alarm signal, a_{lub}/c_{lub_alarm} , is generated. Similarly, starter signals $a_{lub}/c_{lub>start}$ and low-set and high-set trip signals, $a_{lub}/c_{lub>trip}$, and $a_{lub}/c_{lub>>trip}$, are generated, if the associated thresholds are exceeded for the definite times set.



Note

If the natural unbalance has been compensated and the fundamental current in the reference phase (Element1) drops below 10% of the nominal current, the H-bridge unbalance protection functions are suspended, and the compensation vectors are ignored.
If the natural unbalance is not compensated and the fundamental current in the reference phase drops below 10% of the nominal current, the H-bridge unbalance protection function operates only on the amplitude of the measured unbalance current – the phase angle will not be taken into consideration.

The advantage of H-Bridge capacitor bank unbalance protection is that the magnitudes and phase angles of Δa_{lub} , Δb_{lub} and Δc_{lub} are not influenced by any phase imbalance in the supply voltage. Therefore the sensitivity can be much higher than line current unbalance measurement, without spurious tripping caused by unbalanced supply voltages. In addition, this sensitive unbalance protection is now provided independently for each phase of the capacitor bank, thus making it possible to immediately and independently identify the phase and branch in which a change in capacitance has occurred. This is particularly convenient for larger capacitor banks with internally fused or unfused capacitor arrangements, to speed up the identification of faulty capacitor units.

Refer to the figures 5, 8, and 9 in Appendix 3 for further information on this function.



Electrical Distributors

Inputs and Outputs

Element Inputs

Four measuring inputs (Elements 1 to 4) are provided. Each can be programmed to measure inputs from current transformers with nominal currents I_n of either 1A or 5A.

In Normal Mode the Elements 1, 2 and 3 are used to measure the line currents while Element 4 is used to measure the star point unbalance current of a double star connected capacitor bank.

In H-Bridge Mode the Element 1 is used to measure the reference phase current, while Elements 2, 3 and 4 are used to measure the unbalance currents in each of the phases of the H-configured capacitor bank.

Refer to Figure 5 in Appendix 3 for typical configurations.

When programming the RLC04-B it will be noticed that under the Parameter Set-up menu is a sub-menu entitled Set Element 5 variables. Element 5 is a “virtual” and not a physical element. The currents “measured” by this are I_o and I_{lub} which are calculated from the line currents measured by elements 1-4.

Output Relays

The RLC04-B has six relay outputs. Five outputs K1 to K5 are for normal protection use, while the sixth K6 is for the RLC04-B to check its own “health”. To confirm the correct allocation of these output relays a checksum function is available in the unit.

Relays K1 to K5

Relays K1 to K5 can be programmed, separately and in any permutation, to operate in reaction to any alarm/start or trip condition.

The relay outputs can be hardwired to N/O or N/C settings by using the selecting the appropriate links on the RLC04-B's PC board. See the relevant section under Installation and Commissioning.

Output relays K1 - K5 can be programmed to be de-energised or energised in the operational healthy state, and to be latching or non-latching.

For relay contact ratings, refer to Table 5 in Appendix 1. Note that in the RLC04-B product, relay K1 has a higher dc switching capability than K2 to K5, and is intended for the direct tripping of certain switchgear. Caution should be exercised, however, not to exceed the contact ratings of any relay, as this will eventually result in contact failure.

Relay K6 Self-supervisory Output

Relay K6 output is the RLC04-B self-supervisory relay, and its functionality is not user configurable, apart from the N/O or N/C hardware option by using the relevant PC board link.

Output Relay K6 is energised in the healthy power-up normal condition, and de-energises on:

- Loss of auxiliary power supply
- Failure of the RLC04-B internal power supply
- Failure of the microprocessor hardware, software, or memory.

Contact Forms

Output relays 1 to 6 each have one changeover (form C) contact. As default, output relays 1 to 6 are supplied with the normally open (relay de-energized) contacts wired to the terminal block. However, the user may easily change the contacts of any or all of output relays 1 to 6 wired to the terminal block to be normally closed, as required by the application. Refer to Section 5 – Installation and Commissioning for more details on this.



Electrical Distributors

Relay Checksum

Each relay K1 to K5 has an associated checksum which is calculated automatically according to the allocations made during set-up. This calculated checksum is displayed as part of the set-up screens. The purpose is for the user to be able to confirm the correct set-up of K1 to K5, by manually calculating the checksum representing the desired relay set-up and then comparing this with the calculated checksum, which must agree. Refer to Example 1 in Appendix 2 for more details on this.

Digital Input

In addition to the four measuring elements there is an optically isolated digital input, in which the input signal is not measured but is simply detected to see if it is active or inactive. It can be set to have a high level or a low level as being active. A high level must conform to the range 30V - 250V ac or dc and is not polarity sensitive. It can be configured as one of three possible functions, or disabled.

Breaker-On

A signal from an auxiliary contact on the associated circuit breaker is fed into the digital input to signal whether the breaker is open or closed. This signal is used by the undercurrent protection, and can be used by the Breaker Fail 1 protection and Bena function of the relay. If the relay does not receive the Breaker On signal, neither of the mentioned functions will operate.

Event Tripping

The second alternative for the digital input is to create a trip condition based on an active signal on its input. The same input conditions as described above apply, and similarly to other trip condition configurations, any combination of output relays K1 to K5 can be allocated to it. To create a trip, the active signal must remain valid for a pre-set length of time. This Event Input Trip Time (Event:xt) is programmable under the PARAMETER SETUP – Set OTHER functions menu. Should the signal become inactive during this trip time, further activation will begin a new timing sequence starting from zero, even if the reactivation occurs within the original trip time. A suitably descriptive label, downloadable from a computer running the application software, can be programmed to appear following an event trip.

Remote Reset

The third alternative for the digital input is to reset the RLC04-B from a remote location, e.g. a control room. This has the same effect as pressing the red button to acknowledge a trip.

Other Facilities

Password Protection

Certain parts of the menu structure can be protected by an optional password. This provides a measure of security against inadvertent or unauthorized alterations to the relay settings, or clearance of the trip history. Unrestricted access is still provided to the status and test functions.

Test Facilities

While the RLC04-B Relay is in service, it continuously performs various self-testing functions, and if any errors or failures are detected, the corresponding error code(s) will be displayed, and the self-supervision output relay will de-energize, to signal the malfunction. These self-tests include tests of the processors as well as the memory of the device. All protection functions continue uninterrupted during this process.



Electrical Distributors

In addition, a further set of hardware diagnostic tests may be performed on the RLC04-B by the user to test and check the functionality of the digital input, relay outputs, LCD display and LED's. Note that some protection functions may be interrupted during this process.

PC Based Software Package

A Windows 95/98/ME/2000/NT/XP based software package is available for the RLC04-B to exploit its communication facilities. This software package enables the user to create, edit, save, open and print any number of the RLC04-B set-up files on a PC, and to download or upload a set-up file to or from the relay, either directly or via a modem. This is carried out using the Strike communications protocol. In addition, all the other facilities and functions of the serial data port can be exploited using this software package.

Modbus Protocol

The RLC04-B supports the MODBUS RTU protocol for integration of the relay into a SCADA environment. Further information on the implementation can be provided upon request.



Electrical Distributors

Hardware Description

Enclosure and Draw-out Unit

The RLC04-B is housed in a draw-out chassis within a fixed case. This housing is particularly suitable for both flush mounting and 19 inch rack mounting. The case is designed for use in tropical climates, and is designed to withstand shock, vibration and the ingress of dust and moisture. Two phosphor bronze earth continuity strips riveted to the draw-out chassis make contact with earthing strips in the fixed case.

Terminals

A terminal block, with 28 recessed terminals, is provided on the rear of the fixed case. Standard M4 screw terminals (cable lugs with M4 and lug outer diameter < 8 mm), or fast-on connectors (4,8 mm width / 0,8 mm thickness), can be used on the terminal block for connections to the protection relay. Removing the draw-out chassis from the fixed case automatically short circuits the current transformer field terminals, before breaking contact with the draw-out chassis, and ensures that the current transformer circuits are not open circuited during and after removal.



Caution

The RLC04-B incorporates static sensitive devices. However the electronic circuits are well protected by the fixed metal case. Therefore do not withdraw the draw-out chassis unnecessarily. Refer to the section on Installation for further details on handling of the draw-out chassis when removed from the fixed case.

User Interface

A menu driven interface is provided on the front panel. This allows convenient viewing of operational information as well as programming facilities for relay set-up, and access to certain test aids for verification purposes.

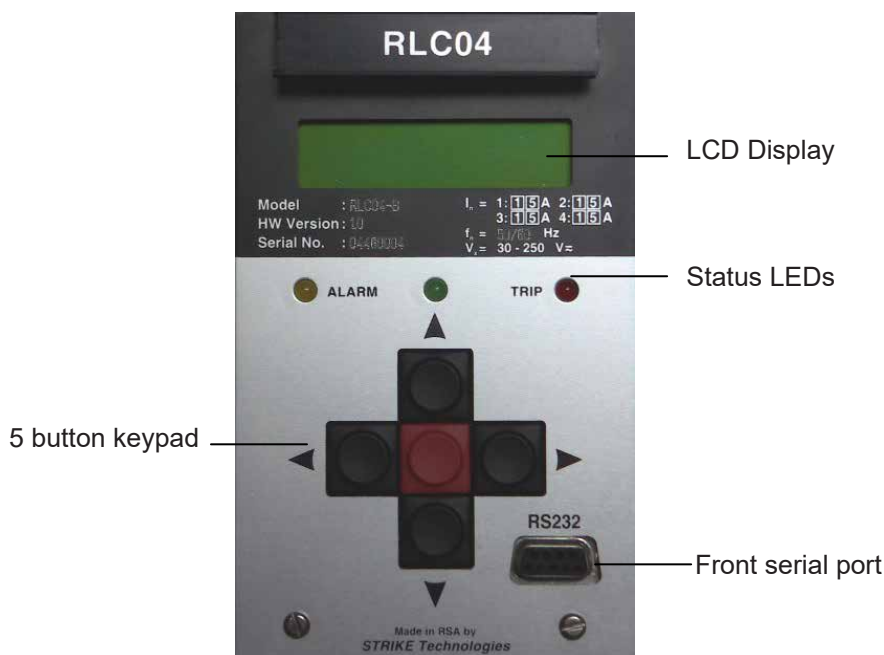

Five button keypad.

The four black buttons are for scrolling left, right, up and down, and the red button is an “Accept” or “Enter” button, for confirming an entry or value, during set-up, for navigating backward or forward in the menu structure, or for accepting a trip annunciation condition, to allow the display to resume its normal running status.

The up and down buttons are used for scrolling through values during set-up. Holding the button in will result in the scroll speed increasing.

Status LEDs

There are three status indicators:

Power On (Healthy) . This green LED is normally on continuously indicating that power is applied, and the relay is in a healthy state. A flashing state indicates that the relay is in the process of completing its on-line diagnostic test.

Alarm/Start . This Yellow LED may be illuminated by an Alarm or a Start condition, depending upon the set-up of the relay.

Trip . This red LED is illuminated when a trip condition occurs and remains on until the trip condition, with its post-trip display, is cancelled by pressing the red “accept” button on the keypad. If multiple trip conditions were present at the time of trip, each condition must be sequentially accepted before the red LED will go off.



The value of the lth>:xt can be set to “Alarm”. This is only used to signal the alarm condition via one of the output relays. It is not linked to the yellow LED.

Note



Electrical Distributors

LCD Display

This 2 line x 16 character alpha-numeric display provides most of the information feedback to the operator. It has a backlight which extinguishes after 1 minute of keypad inactivity. Pressing any button after this will light the display once more. The function of that button is ignored for this purpose.

It supplies the following information:

- During normal relay operation – the display of various measured and calculated parameters, together with the low-set thresholds associated with these parameters.
- After a relay trip condition – annunciation of the entire fault conditions, including the value of the fault currents and voltages at the instant of trip, the information in which phase the max. / min. value occurred and the relay trip time after commencement of the fault condition.
- During relay configuration – interactive configuration of the protection relay.
- During testing of the protection relay – interactive self-testing of the protection relay.
- In the event of the RLC04-B Relay failure – annunciation of any protection relay hardware, software or memory failures detected during self-testing of the RLC04-B Relay, by displaying certain error codes. These are for use by the manufacturer.

Serial Data Port

The RLC04-B is provided with two serial data ports which can be used simultaneously.

One port (RS232 only) is situated on the front fascia and a second port (RS232/485 software selectable) via the terminal block on the rear of the relay.

The front port enables short distance point-to-point communication between a host (typically a lap-top computer) and a single RLC04-B Relay, using the RLC04-B communication software or the MODBUS RTU protocol. As well as setting up the relay and uploading information, firmware upgrades can be downloaded to the relay via this port using a special upgrade program.

The rear port can be used in RS232 mode with a local host PC or other device, or with a modem. Alternatively in RS485 mode it is typically used in a long distance multi-drop communication arrangement between a host PC and several relays.

Auxiliary Power Supply

A high efficiency, low loss, wide range ac/dc auxiliary power supply provides power to the unit relay. This allows the RLC04-B to cater for supply voltages of between 30 V and 250 V ac/dc.

See Appendix 3 for detailed information regarding the operating ranges and further details.



Electrical Distributors

Installation and Commissioning

Unpacking, Storage and Handling

Upon receipt, the RLC04-B should be examined to ensure no obvious damage occurred during transit. Care must be taken when unpacking so that none of the parts are damaged. Check that the product delivered corresponds with that ordered.

If the relay is not to be installed immediately upon receipt, it should be stored in a location free of dust and moisture in its original cartons. The allowable storage temperature range is -20°C to +70°C.

When handling the draw-out module outside the fixed metal case, care should be taken to avoid contact with the electronic components and electrical connections. If removed from the case for storage and/or transport, the draw-out module should be placed in an anti-static bag.



Caution

The RLC04-B incorporates static sensitive devices. However, the electronic circuits are well protected by the fixed metal case. Therefore do not withdraw the draw-out unit unnecessarily

If it is necessary to withdraw the RLC04-B module from its housing, the following precautions should be taken:

- Before removing the draw-out module, ensure that you are at the same electrostatic potential as the equipment, by touching the fixed metal case.
- Handle the draw-out module by the metal fascia plate, frame or edges of the printed circuit boards. Avoid touching the electronic components, printed circuit board tracks or connectors.
- If the equipment is to be passed to another person, first ensure you are both at the same electrostatic potential, by touching.
- Place the draw-out module on an anti-static surface, or on a conducting surface, which is at the same potential as you.
- Store or transport the draw-out module in an anti-static bag.

Further information on safe working procedures for electronic equipment can be found in the relevant national and international standards.

Enclosure and Draw-Out Unit

The RLC04-B is mounted on a draw-out chassis which slides into a fixed case. This housing is particularly suitable for both flush mounting and 19 inch rack mounting. The case is designed for use in tropical climates, and is designed to withstand shock, vibration and the ingress of dust and moisture.

Two phosphor bronze earth continuity strips are riveted to the draw-out chassis and make contact with the earthing strips in the fixed case.

In order to remove the draw-out chassis, unscrew by a quarter turn the bottom catch of the removable front cover and remove by pulling its bottom edge.

Then firmly and slowly pull the draw-out handle on the front fascia plate to remove the draw-out chassis of the RLC04-B.

In order to insert the draw-out chassis into the fixed case carefully align the guide rails on the draw-out chassis with the corners of the fixed case. Then firmly and slowly push the handle on the front fascia plate to insert the draw-out chassis into the fixed case. When the chassis is almost fully inserted, an extra resistance will be felt as the moving contacts on the draw-out chassis mate with the

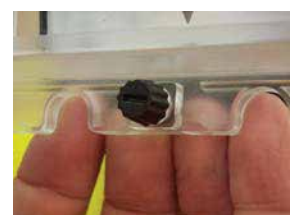
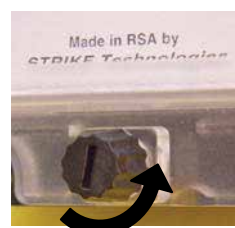

contacts of the fixed case. At this point, press the handle very firmly to fully insert the draw-out chassis. Then place the front cover by hooking the top catch over the clip on the fixed case. Align the front cover and refasten the bottom catch by a quarter turn.

Configuring the Hardware Prior to Installation

Output relay contact form

Output relays 1 to 6 each have one changeover (form C) contact. As default, output relays 1 to 6 are supplied with the normally open (relay de-energized) contacts wired to the terminal block. However, the user may easily change any or all of the contacts of output relays 1 to 6 wired to the terminal block to be normally closed, as required by the application. To do this, withdraw the draw-out chassis from the fixed case, as detailed taking note of the handling requirements.

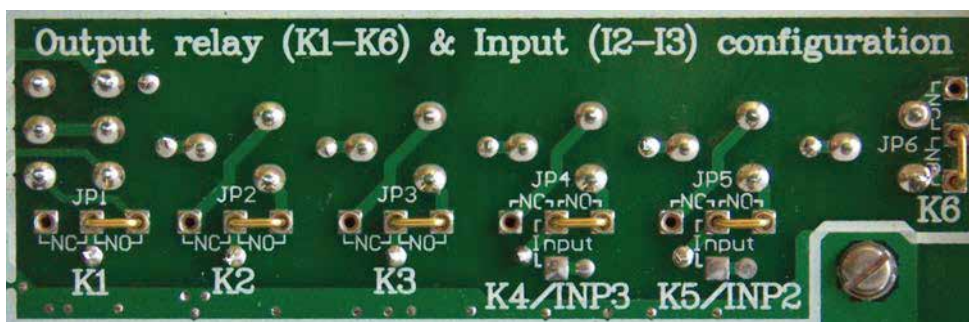

Then, referring to figure above, identify the relay N/O and N/C selection links, on the Analogue / Power supply printed circuit board. Move the link to the desired position for each relay, to select the appropriate contact form.

Mounting

The RLC04-B can be mounted anywhere that meets the environmental specifications as detailed in Appendix 2, and in particular it should be mounted indoors, in a clean, dry atmosphere, out of direct sunlight, and free from excessive dust and vibration.

Refer to Figure 1 in Appendix 3 for details of outline dimensions, cut-out details and mounting holes.



Heat producing devices must be located at sufficient distances away to ensure that the maximum operating temperature of the RLC04-B relay is not exceeded.

The RLC04-B is normally used as a flush mounted or 19 inch rack mounted instrument, for fitting on or within switchgear or relay panels. The relay should be mounted at a convenient height above floor level to facilitate optimum visibility and operator interaction.

The mounting holes of the fixed metal casing of the RLC04-B are accessible without removing the front cover and/or the draw-out module. Therefore it is strongly recommended that the draw-out module should remain protected by the fixed metal case during mounting and assembly of a RLC04-B into a panel or 19 inch rack.



Electrical Distributors

Wiring

All current transformer, auxiliary voltage, output relay, digital input, and rear data port wiring connects to the terminal block with 28 recessed terminals on the rear of the fixed casing. The terminals are clearly labelled.

Auxiliary power supply

Wire the auxiliary power supply to terminals 5 and 7.

The auxiliary power supply terminals can accept ac or dc input voltages and are not polarity sensitive.



Caution

Check carefully before energizing, that the auxiliary voltage falls within the range indicated on the RLC04-B. Ensure that the auxiliary supply to the RLC04-B is adequately protected by means of fuses or miniature circuit breakers to suit the fault level and wire size used as well as the inrush current. High rupturing capacity fuses (2A) are recommended.

Ensure that the power supply to the relay is capable of handling the necessary inrush current. This can be estimated using the following equations:

$$\text{DC supply: } I = V_{DC} / 10$$

$$\text{AC supply: } I = V_{AC} / 20$$

Current transformer circuits

Connect the current transformer connections for elements 1, 2, 3 and 4 to terminals 21 & 22, 23 & 24, 25 & 26, and 27 & 28 respectively.



Caution

One side of each CT circuit should be earthed, and multiple earth connections and earth loops should be avoided.

Check carefully, before applying current transformer inputs, that the current transformer rated currents are correct and correspond with the nominal rated currents of the relevant measuring elements. Refer to Table 5 in Appendix 1 for the acceptable current range, the short-time Over-current, and the VA burden of the measuring elements.



Warning

Extremely hazardous voltages can appear across the CT secondaries if the CT secondary current is open circuited. Do not attempt to connect, disconnect, service or insert other devices in the CT secondary current loops without positively switching off the primary circuit, and thus ensuring that the secondary current is zero.

Output Relay Circuits

Connect the output relay circuits to the terminals of output relays K1, K2, K3, K4, K5 and K6 to terminals 10 & 12, 14 & 16, 18 & 20, 13 & 15, 17 & 19 and 2 & 4, respectively.



Caution

Check carefully before applying voltage to the output relay contacts that the loads and voltages to be applied are within the ratings of the relay contacts. Refer to Appendix 1 for the continuous thermal rating, the short time current rating, the making/breaking capacity, the maximum switching voltage and the maximum switching current of the output relays.

Ensure that the voltages applied to the output relay contacts are adequately protected by means of fuses or miniature circuit breakers to suit the fault-level, wire size and contact rating.



Electrical Distributors

Digital Input

If applicable, connect the digital input circuits to terminal numbers 9 and 11. The digital input terminals can accept ac or dc input voltages and are not polarity sensitive.



Check carefully before applying voltage to the digital input terminals that the voltage applied is correct and falls within the range detailed in Appendix 1.

Ensure that the voltage applied to the digital input is adequately protected by means of fuses or miniature circuit breakers to suit the fault level and wire size used. Highrupturing capacity fuses (2A) are recommended.

Serial Communication Port

If required, wire the Rx, Tx and common terminals (6, 8 & 3 respectively). Note that for RS232 a “crossover connection” is required i.e. the Rx of the RLC04-B must be wired to the Tx of the host device and vice versa. For RS485 models, the multi-drop wiring between RLC04-Bs and the wiring from the first RLC04-B to the host RS485 port, is Rx to Rx and Tx to Tx, i.e. not “crossed over”. For RS485 applications, to obtain the best results in environments with high electrical noise, it is recommended that the last device in the line be terminated with a 120Ω resistor connected between terminal 6 (Rx-) and terminal 8 (Tx+) on the rear terminal block of the relay.

Earth Connection

It is recommended that a 4mm² earth conductor be installed from the RLC04-B earth terminal to the panel earth bar. In addition, ensure that the panel is properly earthed in accordance with local regulations.



For personnel safety as well as not to adversely affect the RLC04-B by surges, transients and other electrical and electro-magnetic disturbances, it is essential that the relay is properly earthed as detailed above.

Noise Isolation

When properly connected and earthed, RLC04-Bs are highly tolerant of electrical and electro-magnetic noise. Refer to Table 4 in Appendix 1 for the withstand ability. However, as with other microprocessor based measurement and protection equipment, the RLC04-B must be installed, wired and located with some degree of concern for electrical and electro-magnetic noise which could cause erratic operation. The relay should be wired, mounted and isolated from sources of potential noise and disturbances in excess of those prescribed in Appendix 1.

In extreme cases this may require that filters or surge suppressors be applied to electro-magnetic devices operating in close proximity to the RLC04-B.

To avoid possible problems from electrical and electro-magnetic noise and disturbances, or if specific problems are experienced in this regard, obtain specialist advice regarding counter measures and solutions.



Performing any changes to element variable or other settings, changes to output relay configurations, or running the diagnostic test sequence to test the output relays, may cause the associated circuit breaker to trip. This could cause serious system disruption. Therefore the greatest care should be exercised when performing these functions on-line, and the user should have a thorough knowledge of this entire manual as well as the particular application and system.



Electrical Distributors

Fully commissioning the relay involves programming it to the required configuration. It is necessary to read and fully understand the following two sections with regard to this. Thereafter the complete step by step installation and commissioning table in Appendix 1 can be referred to as a quick guide.

Navigating the RLC04-B Menu

1st Level Menus

When first switched on, and in its normal operating mode, the RLC04-B displays one of a selection of running displays described in further detail in the section Operating the RLC04-B.

In order to set up the relay, to operate it in anything more than its most basic use, or to test the unit, it is necessary enter the Menu Mode. Despite the number of programmable parameters, and the amount of information that can be extracted from the relay, it is a relatively simple and intuitive process. It is achieved by using just the five buttons on the front panel, the horizontal scrolling buttons ◀ and ▶, the vertical scrolling buttons ▲ and ▼, and the red “accept” button ■.



Note

When in menu mode, whether merely viewing information, or changing parameters, the protection remains in operation and is not compromised in any way. The previous parameters remain in force, until the “Save” action is activated, whereupon the changed parameters come into force.

To enter the menu press both horizontal scroll buttons ◀ and ▶ simultaneously for five seconds.



If a unique password has not been defined, no password will be requested and the display will switch straight to the Access PARAMETER SETUP menu screen in the main menu list.

Type Password
000000

If a password has been set, you will be requested to enter it. This is a 6 digit numeric code. For each digit scroll to the correct number using the ▲ or ▼ buttons.

Move to the previous and next digits by using the ◀ and ▶ buttons respectively.

000110

The digit being addressed will be indicated by a cursor - a line beneath the digit.

Once you have set all 6 digits correctly, press the red button ■ to enter.

There are nine main menus available which can be scrolled through using ◀ and ▶.



Note

When shipped, the default password is 000000, which allows unrestricted access to all menu functions. By setting a new password the valid password must be entered to access to any interactive menu. This provides a measure of security against inadvertent or unauthorized alterations to the relay settings. Unrestricted access is still provided to the status and test functions, by pressing ■ instead of entering the password.

Some of these are used for programming the RLC04-B, and some for normal operation such as extraction of information, and for testing:

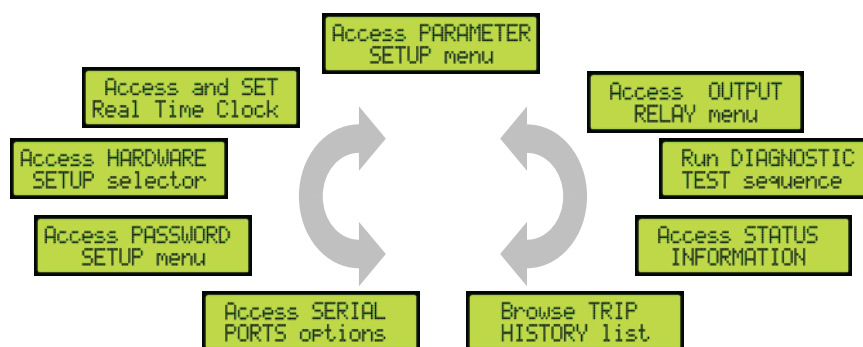

When viewing one of these 9 main 1st level menus, access the 2nd level beneath it by pressing ▼. In the case of the Parameter Set-up option, the 2nd level consists of a further series of menus. For the other options it will be a series of parameter adjustment, information, or test screens depending upon the option.

2nd Level Menus

Once you have gone down to the 2nd level of the Parameter Set-up option, scroll through these menus using ◀ and ▶. Access them by pressing ▼. Return from the 2nd level menu list to the 1st level menus by pressing ■. An exit process described below allows you to save or discard any adjustments made, or to return to make further adjustments.

Changing or Selecting Parameters

After accessing a parameter adjustment level from the menu above it, the various screens, and the items within a screen, are scrolled through using ◀ and ▶. Parameters are adjusted or choices normally made by using ▲ and ▼.



Note

When arriving at a parameter adjustment screen after pressing ▼ from a menu above it, take care not to keep ▼ pushed in for too long or a parameter may be inadvertently adjusted.



Electrical Distributors

Some Exceptions

Some sub-menus do not follow the general rules described above.

Trip History	Scroll vertically to select a particular trip.
	Scroll horizontally for information on a particular trip
Password Set-up	Scroll through screens using

Scrolling

As described above, displays and parameters can be scrolled in either direction and values can be incremented or decremented, by using the appropriate buttons. Generally scrolls in the forward direction and in the reverse direction; increments and decrements a value or toggles an option. Holding a scroll button down scrolls continuously. All scrollable sub-menus and parameters are of the “wraparound” type i.e. last wraps around to first. When held down, the scroll speed gradually increases the longer the button is held.

Usually, once a parameter has been set to a value, or choice, the operator simply scrolls to the next item. All items on a submenu are saved together in one operation. This occurs when exiting the sub-menu.



Note

When programming the RLC04-B, it is important that any function that is not required must be disabled, to prevent confusion and possible spurious operation. Disable is an available option when scrolling a value, or selecting from possible choices.

The Exit Process

To revert to the next higher level menu press .

When exiting a screen from within the Diagnostic Test or Status Information options, or the 3rd level screens from within the Parameter Set-up option, this is all that is needed.

To revert to the 1st level menu from other menus where parameters may have been adjusted, use and to choose between the following options which are presented to you:

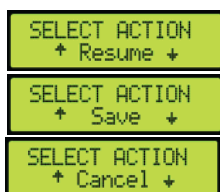

Re-enter the menu to make further changes

Save the changes made and exit the menu

Exit the menu without making any changes since the last save

Press to have your choice accepted and conclude the exit process.



Note

When “Save” is selected, there will be a short delay while the new parameters are saved into the non-volatile memory.

To revert to the running displays from the 1st level menus, press both and simultaneously.



Note

If the relay is inadvertently left in menu mode, it will automatically perform a “cancel” operation and exit to the running displays after 10 minutes.

In the three sections of this manual that follow, the symbols , , , , or appearing at the beginning of a line of text indicate that the relevant button should be pressed to change to the display to that which will be described.



Electrical Distributors

Programming the RLC04-B

Enter menu mode as described in the preceding section. Of the 9 first level menus the following 6 are used to set-up the relay operating parameters. They all fall under the protection of the optional password. The first 4 set-up menus are common to both Normal and H-Bridge Modes:

Hardware
Serial Ports

Password
Real-time Clock

The last two set-up menus offer different options which are mode dependent:

Parameters

Output Relays

Configuring the Hardware

The options here offer settings for the most fundamental operating configuring of the RLC04-B.



▼ Access the Hardware Setup selector 2nd level screens.



The first screen allows the relay to be set in Normal or H-Bridge mode by toggling the options with ▲ and ▼.

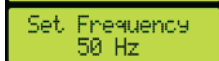



► Scrolling right allows the system frequency to be entered into the relay, toggling between 50 and 60Hz with ▲ and ▼.

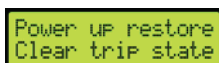

► The next 4 screens allow the Element inputs 1 to 4 to be individually set for use with current transformers with either 1A or 5A nominal secondary currents by toggling with ▲ and ▼.



► The final screen allows the RLC04-B response to be determined upon restoration of power following an outage. The options of Clear trip state or Hold trip state are toggled with ▲ and ▼.

Exit using the standard  - Resume/Save/Cancel -  process.

Setting the Password

Setting a password is optional - Refer also to the Password Protection under Other Facilities in Section 3 - Functional Description, and also Section 6 - Navigating the RLC04-B Menu.



▼ Access the Password Setup 2nd level screens.



Enter the old password. Set each digit using ▲ and ▼ and scroll between digits using ◀ and ▶. If the password has not been previously defined, leave it at all zeros.

 Progress to the next step.



Enter the new password by defining a 6 digit numeric code in a similar manner.

Exit using the standard  - Resume/Save/Cancel -  process.



Keep the password in a secure place. Losing the password will mean that access to the protected functions will be denied, causing substantial inconvenience.

Note



Electrical Distributors

Serial Port Options

This function only needs to be set if either of the serial ports are to be used.

Access SERIAL
PORTS options

▼ Access the Serial Ports options 2nd level screens.

Baudrate FRONT
115200

Choose the baud rate for the front port using ▲ and ▼. Choose from the seven rates between 2400 and 115200 using ▲ and ▼. For a short distance connection to a laptop computer the highest setting of 115200 is normally used.

Parity FRONT
EVEN

▶ Scrolling to the right allows the setting of the parity to EVEN, ODD, or NONE, using ▲ or ▼.

Comms type REAR
RS232

▶ Scroll right to set the type of serial connection for the rear port. Choose between RS232 and RS485 using ▲ or ▼.



Note

In some applications e.g. with some modems, in high electrical noise environments, or long transmission distances, a lower rate may be required to achieve error-free communication. Data transfers will naturally take longer at the lower rates, although because the data is quite compact, this may not be noticeable.

▶ The next two displays allow the setting of the baudrate and parity for the rear port in the same way as for the front port described above.

Comms. Address
1

▶ Scrolling further to the right displays the applicable settings for the Modbus communications protocol. Firstly is the address of the particular relay. Choose from the values 1 to 255 using ▲ and ▼.

MODBUS Response
Time = 0.50

▶ Next is the Modbus response time. Choose from the range 0.01 to 10.00 seconds using ▲ and ▼.

MODBUS Dead
Time = 0.50

▶ Set the Modbus dead time from the range 0.01 to 10.00s using ▲ and ▼.

ModbusForceRelay
Time = 1.0s

▶ Finally set the Modbus Force Relay Time from the range 0.1 to 60 seconds using ▲ and ▼.

Note that an understanding of the operation and requirements of Modbus RTU, as well as the specific application, is required to decide on appropriate settings for these parameters. If it is not intended to use Modbus in the applications, these settings can be ignored.

Exit using the standard - Resume/Save/Cancel - process.



Setting the Real-time clock

Access and SET
Real Time Clock

▼ Access the Set Real-time clock 2nd level screens.

Set Time
12:34:56

Adjust each of the three values of hours, minutes, and seconds using ▲ or ▼, and scroll between them using ◀ and ▶.

Set Date
Mon 17/01/2005

▶ Scroll right to change to date. Adjust each of the four values of day of the week, day, month, and year using ▲ or ▼, and scroll between them using ◀ and ▶.

Exit using the standard ■ - Resume/Save/Cancel - ■ process.

Parameter Setup - Normal Mode

Access PARAMETER
SETUP menu

▼ Access the Parameter Set-up sub-menus.

Use ◀ and ▶ to scroll through the following 2nd level menus, before using ▼ to access the 3rd level screens:

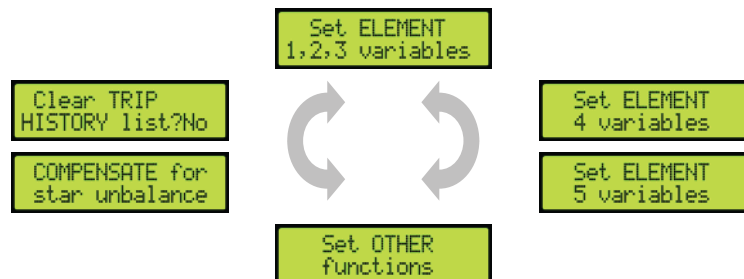

Set Element 1, 2, 3 Variables

Icr/In = 1.00
Range= 0.25-1.50

Set the Icr/In (capacitor rated current-to-CT nominal current) ratio to a value within the range 0.25 to 1.50 using ◀ and ▶.

▶ Further scrolling to the right allows the setting of the other parameters for Elements 1 to 3 in the same way:

vc>al/vcr	vc>al:xt	vc>/vcr	vc>>/vcr	vc>>:xt	vc>reset	lth>/ln
lth>:xt	lth>>/ln	lth>>:xt	<input type="checkbox"/>	l1>/ln	l1>:xt	l1>>/ln
l1>>:xt	l1</ln	l1<:xt	lrms>/ln	lrms>:xt	lrms>>/ln	lrms>>:xt

Revert to the 2nd level menus by pressing ■.



Set Element 4 Variables

In the same fashion as for Elements 1 to 3, the following Element 4 variables can be set:

lub al/In	lub al:xt	lub>/In	lub>:xt	lub>>/In	lub>>:xt
-----------	-----------	---------	---------	----------	----------

Revert to the 2nd level menus by pressing .

Set Element 5 Variables

In the same fashion as for Elements 1 to 3, the following Element 5 variables can be set:

lo>/In	lo>:xt	lo>>/In	lo>>:xt
llub>/In	llub>:xt	llub>>/In	llub>>:xt

Revert to the 2nd level menus by pressing .

Set Other Functions

INPUT function
+ Remote Reset +

Using ▲ or ▼, select between Breaker-Bon, Remote Reset, Event Trip, or Disabled for the Digital input function.

InputActive when
Con.Voltage=High

► Toggle between active high or low for the digital input using ▲ or ▼.

Event:xt= 0.03
Range=0.03-600.0

► Select the Event:xt time-out value using ▲ and ▼. This is only relevant if the digital input function has been set to Event.

Bfail1:xt = N/A
Range = 0.01-2.0

► Set the Bfail1:xt time-out value using ▲ and ▼. If the Bfail1 function is not required, set Bfail1:xt to N/A.

Bfail1 released:
Ifund<10%In

► Set the Bfail1 release condition using ▲ and ▼. Select from Ifund<10%In, Dig-Input, Ifund AND Input, or Ifund OR Input. The latter 3 conditions are only relevant if the digital input function has been set to Breaker-Bon.

Bfail2:xt = N/A
Range = 0.01-2.0

► Set the Bfail2:xt time-out value using ▲ and ▼. This is only relevant if the digital input function has been set to Breaker-Bon. If the Bfail2 function is not required, set Bfail2:xt to N/A.

Bena:xt = N/A
Range = 1 - 1200

► Set the Bena:xt time-out value using ▲ and ▼. This is only relevant if the digital input function has been set to Breaker-Bon.

Bena trigger by:
Ifund<10%In

► Set the Bena trigger condition using ▲ and ▼. Select from Ifund<10%In, Dig-Input, Ifund AND Input, or Ifund OR Input. This is only relevant if the digital input function has been set to Breaker-Bon.

Start LED shows:
Only trip STARTS

► Using ▲ or ▼, select between Only trip STARTS, Only ALARMS, STARTS and ALARMS, or always off.

Revert to the 2nd level menus by pressing .



Compensate for Star Unbalance

Compensation of the natural unbalance current can only be done after the relevant capacitor bank or filter circuit is in service.

```
COMP. vector
--%  Z---.-'
COMP. vector
3.4%  Z356.9°
```

The display initially shows the magnitude and angle of the compensation vector. The examples here show instances where the system is firstly uncompensated, and secondly a typical screen for a compensated system.

```
Iub --%  Z---.-'
Compensate? No
Iub 2.3%  Z176.9°
Compensate? No
```

► Scrolling right shows the calculated unbalance current, either in absolute terms if uncompensated, or in relative terms, ΔI_{ub} , if compensated. To compensate the system toggle the display to Yes with ▲ or ▼ and press ■.

After compensation, the compensation vector has the same magnitude as the initial measured fundamental frequency unbalance current at the instant of compensation, but has the opposite polarity (i.e. is 180° out of phase).

Immediately after compensation, ΔI_{ub} will always be the null vector.

However, after compensation any subsequent change in capacitance will cause ΔI_{ub} to assume a non-zero magnitude and some phase angle ranging from 0° to 360°. The magnitude of ΔI_{ub} is a measure of the change in capacitance in any leg of the double star capacitor bank arrangement. The phase angle of ΔI_{ub} indicates the leg in which the change in capacitance has occurred. Refer to figure 8 and 9 in Appendix 3 for further details on this.

```
Uncompensate
No
```

► The next screen allows the user to clear the existing compensation from the system by toggling the display to Yes with ▲ or ▼ and pressing ■. The display then reverts to the previous screen.

Revert to the 2nd level menus by pressing ■.

Clear Trip History

This consists of a single screen. Use ▲ to toggle between Yes and No.

From any of the 2nd level menus, exit using the standard ■ - Resume/Save/Cancel - ■ process.

Output Relay Setup – Normal Mode

```
Access OUTPUT
RELAY menu
```

▼ Access the Output Relay set-up screens.

```
Relay : #12345
vc>alarm 00000
```

The first screen allows the user to allocate any combination of the 5 output relays to a vc>alarm signal. The relay being addressed is denoted by the cursor. Use ▲ or ▼ to toggle between 0 (de-allocated) and 1 (allocated). Scroll between relays and subsequent screens using ◀ and ▶

By scrolling to the right the output relays can be allocated to the following signals in the same way:

vc>start	vc>trip	vc>>trip	I1>start	I1>trip	I1>>trip
Irms>start	Irms>trip	Irms>>trip	Ith>start	Ith>trip	Ith>>trip
I1<trip	Iub_alarm	Iub>start	Iub>trip	Iub>>trip	Io>start



Electrical Distributors

lo>trip	lo>>trip	llub>start	llub>trip	llub>>trip	B fail 1
B fail 2	B era	Event_trip			

```
Energise #12345
to trip  11111
```

```
Latch #12345
on trip 00000
```

```
RELAY#1 Checksum
000000
```

► The next screen allows the user to select for each relay whether it is normally energised (1) or de-energised (0) in the healthy state.

► Select for each relay whether it latches upon a trip, and would subsequently need to be reset, or whether it resets automatically after the fault causing the trip has cleared.

► The next 5 screens show the internally generated checksums for each relay. Performing a manual calculation of these checksums and comparing the two, provides a double check that the relays have been allocated correctly. See Appendix 2 for more details on this.

Revert to the 1st menus using the standard - Resume/Save/Cancel - process.

Parameter Setup – H-Bridge Mode

```
Access PARAMETER
SETUP menu
```

▼ Access the Parameter Set-up 2nd level menus.

Use ◀ and ▶ to scroll through the following 2nd level menus, before using ▼ to access the 3rd level screens:

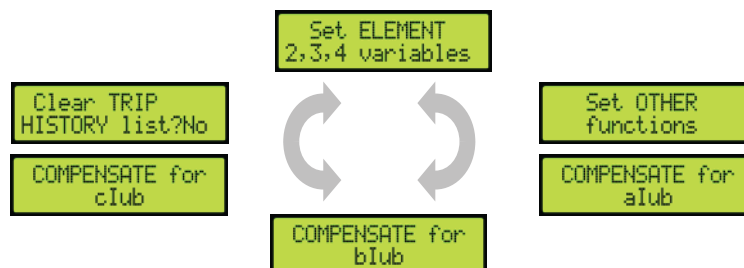

Set Element 2, 3, 4 Variables

```
aIub_al/In= N/A
Range = 0.01-2.0
```

Set the alarm threshold within the allowed range using ▲ and ▼

```
aIub_al:xt= 0.1
Range= 0.1s-600s
```

► Next adjust the time-out value associated with the alarm threshold.

Further scrolling right will allow the user to adjust the low-set and high-set thresholds with their associated timers for alub, as well as all of the similar settings for blub and club.

Revert to the 2nd level menus by pressing .



Electrical Distributors

Set Other Functions

```
INPUT function
+ Remote Reset +
```

Using ▲ or ▼, select between Remote Reset, Event Trip, or Disabled for the Digital input function.

```
InputActive when
Con.Voltage=High
```

► Toggle between active high or low for the digital input using ▲ or ▼.

```
Event:xt= 0.03
Range=0.03-600.0
```

► Select the Event:xt time-out value ▲ and ▼. This is only relevant if the digital input function has been set to Event.

```
Start LED shows:
Only trip STARTS
```

► Using ▲ or ▼, select between Only trip STARTS, Only ALARMS, STARTS and ALARMS, or always off.

Revert to the 2nd level menus by pressing .

Compensation for xIub

The following description applies to the sub-menus Compensate for aIub, Compensate for bIub, and Compensate for cIub, which are each compensated separately.

Compensation of the natural unbalance current can only be done after the relevant capacitor bank or filter circuit is in service.

```
comp. vector
--% z---.-°
```

The display initially shows the magnitude and angle of the compensation vector. The examples here show instances where the system is firstly uncompensated, and secondly a typical screen for a compensated system.

```
comp. vector
3.4% z356.9°
```

```
aIub --% z---.-°
Compensate? No
```

► Scrolling right shows the calculated unbalance current, either in absolute terms if uncompensated, or in relative terms, ΔI_{ub} , if compensated. To compensate the system toggle the display to Yes with ▲ or ▼ and press .

```
aIub2.3% z176.9°
Compensate? No
```

After compensation, the compensation vector has the same magnitude as the initial measured fundamental frequency unbalance current at the instant of compensation, but has the opposite polarity (i.e. is 180° out of phase).

Immediately after compensation, the compensated current, ΔI_{ub} , will always be the null vector.

However, after compensation any subsequent change in capacitance will cause ΔI_{ub} to assume a non-zero magnitude and some phase angle ranging from 0° to 360°. The magnitude of ΔI_{ub} is a measure of the change in capacitance in any leg of the double star capacitor bank arrangement. The phase angle of ΔI_{ub} indicates the leg in which the change in capacitance has occurred.



```
Uncompensate
No
```

► The next screen allows the user to clear the existing compensation from the system by toggling the display to Yes with ▲ or ▼ and pressing . The display then reverts to the previous screen.

Revert to the 2nd level menus by pressing .

Clear Trip History

This consists of a single screen. Use ▲ to toggle between Yes and No.

From any of the 2nd level menus, exit using the standard  - Resume/Save/Cancel -  process.



Electrical Distributors

Output Relay Set-up - H-Bridge Mode

```
Access OUTPUT
RELAY menu
```

▼ Access the Output Relay set-up screens.

```
Relay : #12345
aIub_alarm 00000
```

The first screen allows the user to allocate any combination of the 5 output relays to an alub alarm signal. The relay being addressed is denoted by the cursor. Use ▲ or ▼ to toggle between 0 (de-allocated) and 1 (allocated). Scroll between relays and subsequent screens using ◀ and ▶

By scrolling to the right the output relays can be allocated to the following signals in the same way:

alub>start	alub>trip	alub>>trip	blub_alarm	blub>start	blub>trip
blub>>trip	club_alarm	club>start	club>trip	club>>trip	Event_trip

```
Energise #12345
to trip 11111
```

▶ The next screen allows the user to select for each relay whether it is normally energised (1) or de-energised (0) in the healthy state.

```
Latch #12345
on trip 00000
```

▶ Select for each relay whether it latches upon a trip, and would subsequently need to be reset, or whether it resets automatically after the fault causing the trip has cleared.

```
RELAY#1 Checksum
000000
```

▶ The next 5 screens show the internally generated checksums for each relay. Comparing these to manually calculated ones provides a double check that the relays have been allocated correctly. See Appendix 2 for more details on this.

Revert to the 1st menus using the standard  - Resume/Save/Cancel -  process.



Electrical Distributors

Operating the RLC04-B

The operation of the RLC04-B falls into three categories, Healthy condition, Fault (trip or alarm) condition, and Information retrieval

Healthy Condition

The LED Indicators

In the healthy condition the green LED will be alight.

The Running Displays

After auxiliary power-up, and during normal operation, the LCD can display any of a number of screens showing the instantaneous values of various measured and calculated parameters of the RLC04-B.

These are termed the Running Displays.

For each mode, Normal and H-Bridge, there are two sets of displays.

They are the standard set which are scrolled through using ▲ and ▼, and the extended set which are scrolled through using ◀ and ▶. Each screen in one set has an associated screen in the other set, from which scrolling starts when changing from one set to the other.

The associated screens are shown alongside each other in the full listings of available screens below.

So for example, if the Time & Date screen has been scrolled to using ▲ or ▼, pressing ◀ or ▶ will bring up the Digital Input detail screen. Further use of ◀ or ▶ will display the other screens in the extended set.

Most of the screens show values measured or calculated by the relay and are fairly self-explanatory.

The displays show small indicators for each of the protective function thresholds (alarm: al; undercurrent: < ; low-set: > ; high-set: >>) where they have been set.

This not only allows the user to see which protective functions are set, but furthermore if the function is active the associated indicator starts to blink.

If the relay is not measuring a signal or if the signal is below the suppression level the display will only show --%. In both Normal and H-Bridge modes the Reference phase screen shows the fundamental component of Element 1.

If the Reference phase current falls below 10% of the nominal current I_n , then this has an impact on the way the star point and H-bridge unbalance protection functions operate – see Section 3 – Functional Description for details.

Again applicable for both modes, the last screen in the extended set (adjacent to the Date and Time) shows the state of the digital input. The text reflects the function of the input as follows:

Disabled	Digital Input OFF
Breaker-Bon	Breaker Position (Open or Close)
Remote Reset	Trip Reset State (No trip reset or Trip reset)
Event Trip	Free Text (Inactive text or Active text) which is downloaded using the PC communication program.



Electrical Distributors

Normal Mode Displays

The available displays in Normal Mode are shown in the table below. The three values shown in each of the first four standard set screens are the instantaneous values for the Elements 1, 2 and 3. In the extended set, the maximum value of the three parameters is shown, along with the low set threshold.

Standard (▲ / ▼)	Extended (◀ / ▶)
Cap voltage vc a% --% --% --%	vc max a% --% vc>/vcr = 1.50
Fund. current I1 a% --% --% --%	I1 max a% --% I1>/In = 1.00
Thermal Ith a% --% --% --%	Ith max a% --% Ith>/In = 1.50
RMS current Irms a% --% --% --%	Irms max a% --% Irms>/In = 1.50
Star unbalance a%Δ --% Δ---,-°	Iub a%Δ --% Iub>/In = 1.50
Earth fault Io a% --%	Io a% --% Io>/In = 1.00
Line unbalance a% --%	Ilub a% --% Ilub>/In = 1.00
Reference Phase --%	Bfail1 a Bena a Bfail2 a
12:34:56 Mon 17/01/2005	Breaker Position Open

A typical screen display can look as follows:

```
vc max a% 103%
vc>/vcr = 1.10
```

The screen shows that the low set and high set trip thresholds have been set, but not the alarm, and that the maximum of the capacitor voltage in the three elements is 103%.

If the value would exceed the low set threshold (110%) the low set trip indicator (>) would start to blink, while if the value would exceed the high set threshold, both indicators (> and >>) would blink.

H-Bridge Displays

The available displays in H-Bridge Mode are shown in the table here:

Standard (▲ / ▼)	Extended (◀ / ▶)
aIub bIub cIub --% --% --%	Reference Phase --%
Unbalance aIub a% --% Δ---,-°	aIub a% --% aIub>/In = 1.00
Unbalance bIub a% --% Δ---,-°	bIub a% --% bIub>/In = 1.00
Unbalance cIub a% --% Δ---,-°	cIub a% --% cIub>/In = 1.00
12:34:56 Mon 17/01/2005	Trip Reset State No trip reset

A typical display for a compensated system (indicated by the Δ) will look as follows:

```
aIub a%Δ 1%
aIub>/In = 0.10
```

The screen shows that the alarm, as well as the low set and high set trip thresholds have been set, and that the actual unbalance current in the a-phase is 1%.

If the value would exceed the alarm threshold for the time set, the alarm indicator will start to blink. If the unbalance current exceeds the low set threshold (10%), the low set trip indicator (>) would also start to blink, while if the value would exceed the high set threshold, all three indicators (a| and > and >>) would blink.



Electrical Distributors

Default Display

Upon power up, or when in normal operation no scroll key has been pressed for one minute, the relay will revert to the default display. Upon delivery, the default display for the relay in Normal Mode is the Element 1,2 and 3 repetitive peak capacitor voltage, vc screen, while for the H-Configuration mode the summary screen showing the a-, b- and c-phase unbalance currents is the default display.

Any other of the standard or extended screens can be set as the default simply by pressing  while that desired screen is displayed. The relay will show a short message "New DEFAULT DISPLAY saved".

Fault Condition

The LED Indicators

In a fault condition the green LED will extinguish and the yellow or red LED will light according to the level of fault.

Yellow LED: START – Based on the selected setting of "Start LED shows:" in the "Set OTHER functions" menu the following functionality will be achieved:

Only trip STARTS	The Start LED lights on STARTS which will cause a subsequent trip; ALARMS are ignored
Only ALARMS	The Start LED will flash on ALARMS; STARTS are ignored
STARTS + ALARMS	The Start LED will flash for ALARMS and light up constantly on STARTS which will cause a subsequent trip
Always off	The Start LED will never light.

Red LED: This indicates that a trip condition has occurred that has not yet been acknowledged. Only when all the post trip fault annunciation screen displays have been acknowledged will this LED extinguish.

The Running Display

When one of the set threshold levels has been exceeded, but before a trip has been output, the normal operation screen remains displayed. In addition the small indicators (al, <, >, or >>) on the display start to blink, to signal the active function.

Post-trip Fault Annunciation Displays

Immediately that a trip occurs, the trip information is recorded in the Trip History list. The post-trip annunciation displays described here are actually a sub-set of trip history.



They relate only to the latest trip, and are displayed for the operator's convenience. The set of post-trip data displayed indicates which software trip signals were generated for each trip event.

The magnitude of parameter causing the corresponding software trip signal at the instant of generation is recorded, as well as the time taken from the moment the relevant trip threshold was exceeded, until the software signal was generated. In case of protective functions which operate with values from Element 1, 2 and 3, the post-trip display also shows the Element number in which the maximum or minimum of the parameter occurred as well as the element(s) which have been above the threshold at the instant of trip.

In the case of the star-point and H-Bridge unbalance trip signals, the relevant phase angle of the unbalance current is also recorded, to indicate in which leg of the capacitor bank, capacitor failure has occurred (Refer to Figures 6 to 9 in Appendix 3).



Electrical Distributors

Under normal circumstances, after a trip condition, an operator would assess and note the relevant information from the post-trip annunciation screen, and then acknowledge (i.e. reset) the trip by pressing . At this point, any other trip conditions that may have occurred after the first trip condition, will be displayed. Again the user can acknowledge this indication, by pressing .

After all of the post-trip annunciation screens have been acknowledged, the display reverts to the normal default operating screen.

After investigating and rectifying the fault condition, the operator would normally only then re-energize the tripped circuit breaker. If, however, the tripped circuit breaker is re-energized before the post-trip screens have been acknowledged, then the post-trip annunciation screens will continue to be displayed until they are acknowledged, as previously detailed, after which the normal operation screen, will be displayed.

If a further fault condition were to occur, causing the circuit breaker to trip again, before the previous post-trip screens have been acknowledged, then the previous fault trip data is replaced with the latest data.



Note

It is only possible to acknowledge a trip once the fault has been cleared – the yellow LED must be OFF, otherwise you will only be able to scroll through the post trip data.

Typical Post-Trip Annunciation Displays

Some typical examples of post-trip annunciation displays are shown below.

```
vc>trip 105%  
M3-12 1312s  
vc>>trip 542%  
M1-23 0.05s
```

```
Iub>trip 20%  
z60.2 10s  
Bfail1 10%  
0.10s
```

M3-12 means that Element 3 attained the maximum amplitude at the instant of trip, while elements 1 and 2 were also above the threshold setting.

Information Retrieval

Trip History List

As mentioned above, immediately that a trip occurs, the trip information is recorded in the Trip History list. This list records data for up to 25 trip events.

Trip events which happen during a so-called trip session are pooled together in one group, with No. 1 being the most recent. It is saved in the non-volatile EEPROM memory and is therefore also available after loss of power supply.

With the relay in normal operation, the complete TRIP HISTORY list is accessed by entering Menu Mode.

```
Browse TRIP  
HISTORY list
```

▼ Access the Browse TRIP HISTORY list 2nd level screens.



Electrical Distributors

```
Trip History
Recorded = 10
```

This is an example of the first screen which indicates how many trips are in memory.

◀ and ▶ toggle between the first screen and this screen which shows exactly the when the trip history list was last cleared.

```
Cleared:12:35:46
Thu 13/01/2005
```

When either of the two screens above are being displayed, it is possible to clear the complete trip history by pressing . The following is displayed:

```
Trip History
Clear NOW? No
```

Use the ▲ or ▼ to toggle the “No” to “Yes”. Then press to clear the Trip History list.

This is only possible if the correct password has been entered when accessing Menu Mode, or if no password has been set. Alternatively the trip history can be cleared from within the Parameter Setup menu.

```
N01G01) 12:34:56
Thu 13/01/2005
```

▼ Scrolling down from the Trip History screen, the display shows trip number screen. This indicates the time and date of the 1st (N01) trip of the first trip session (G01).

▶ Scrolling right will reveal the details of the trip over three screens. The first shows the cause of the trip and its magnitude, which elements were affected, and the time it took to trip.

```
I1>trip 150%
M:2- 1.10s
```

The second screen shows the relevant values for all three elements.

```
Fund. current I1
150% 50% 25%
```

The third screen shows which relays were tripped.

```
Relay(s) tripped
1 - 3 - -
```

▶ Scrolling right once more will return to the trip number screen

▼ Scrolling down further will reveal all of the trip number screens in succession, from which the details can be discovered using ◀ and ▶.

When all of the desired TRIP HISTORY list data has been viewed, press to revert to the main menu.

Status Information

(Optional Password Protection – partially)

This menu allows the user to obtain certain information from the relay such as:

Installation information
Output relay status
Setup saved counter

Digital input function
Communication port activity
Protective function trip counters

Enter Menu Mode in the usual fashion.

```
Access STATUS
INFORMATION
```

▼ Access the STATUS INFORMATION 2nd level screens.



Electrical Distributors

```

Install Info.
Programmable mes
Input function
Status = Low
Relay : #12345
Energized= 00000
Front RS232
Tx= OFF Rx= OFF
Rear Comms.
Tx= OFF Rx= OFF
Setup Saved
Counter = 00012
  
```

The first screen displays a moving message of maximum length 100 characters, which can be downloaded from a PC running the dedicated communication software.

► This screen enables the user to check that the digital input is functional. When a voltage is applied to the digital input terminals, the above display should change from Low to High.

► This screen enables the user to check if any of the output relays are energized.

► These two screens (Front / Rear) enable the user to check if the serial data ports are functional. When data is received or transmitted, the respective part of the communication display should change from OFF to ON.

► This screen allows user to check how many times the set-up has been saved on this unit.

Additionally by pressing ▲ or ▼ the date of the last save of set-up information can be accessed.

```

Saved: 12:34:56
Thu 13/01/2005
  
```

The screens which follow are operating mode dependant. They show the trip counters for the individual trip functions together with the time stamp information when the counter has been last cleared.

Relay configured in Normal Mode

```

vc>alarm tripped
Counter = 00012
  
```

► This indicates that the vc>alarm signal has been generated 12 times since the last clearance of the counter.

▲ or ▼ toggle between the above screen and this which shows the date of the last clearance of the counter.

```

Cleared:12:34:56
Thu 13/01/2005
  
```

► The next 20 screens will show the user similar information about the following trip functions:

vc>	vc>>	l1>	l1>>	l1<
lrms>	lrms>>	lth>	lth>>	lub_alarm
lub>	lub>>	lo>	lo>>	llub>
llub>>	Bfail 1	Bfail 2	Bena	Event

Relay configured in H-Bridge Mode:

```

aIub_al tripped
Counter = 00012
  
```

► This indicates that the alub alarm signal has been generated 12 times since the last clearance of the counter.

▲ or ▼ toggle between the above screen and this which shows the date of the last clearance of the counter.

```

Cleared:12:34:56
Thu 13/01/2005
  
```

► The next 9 screens will show the user similar information about the following trip functions:

aIub>	aIub>>	bIub_al	bIub>	bIub>>
cIub_al	cIub>	cIub>>	Event	

Clearing the Counters

Any of these counters can be reset individually if the unit is not password protected, or if the password has been entered correctly upon entry into the main menu.



Electrical Distributors

In order to reset the individual counters perform the following steps:
Select the desired counter using ◀ or ▶. Press the  to select the counter.

The display changes as follows:

```
vc>alarm tripped  
Clear NOW? No
```

Use ▲ or ▼ to toggle between No and Yes, then press  to clear the counter. The time stamp information will be updated accordingly. If No is selected the relay will revert to the Access STATUS INFORMATION menu.



Electrical Distributors

Testing and Troubleshooting

Automatic Self-testing

On application of the auxiliary supply voltage, and at regular intervals in the background during normal operation, the RLC04-B automatically performs a number of diagnostic checks of the:

- EEPROM
- Calibration factors
- EPROM
- RAM
- Processors

Any errors detected will cause the relay to suspend all protective functions, de-energize the self-supervision relay and display an error message as detailed below:

Display Message	Error Description
EPROM Error	Firmware EPROM memory checksum discrepancy
EEPROM Error	Non-volatile EEPROM memory checksum discrepancy
RAM Error	Volatile RAM memory failure
DSP Stopped	DSP watchdog failure

User-performed Diagnostic Tests

During commissioning, while in normal service, or in the test laboratory, a series of diagnostic tests may be performed by the user. These tests enable the user to check functionality, hardware, and certain information as described below.

All protective functions are fully operational while performing these series of diagnostic tests, except during the testing of the output relays!

```
Run DIAGNOSTIC
TEST sequence
Serial Number
01234567
Software Version
4 06 2B-0D-0D
```

▼ Access the DIAGNOSTIC TEST sequence 2nd level screens.

This enables the user to verify that the serial number embedded in the RLC04-B corresponds with that engraved on the fascia plate

► The first 3 digits indicate the software version number. The next 3 double digit groups refer to changes made, to either the User Interface, the Protection software module, or the DSP code.

```
Relay User Code
1234567890
```

► If the user forgets the set password, this code must be included in an official written fax request to Strike Technologies for them to provide to the user a password valid for a single session.

```
Pretest Code
FLOW: ---PASSED
```

► This shows the result of a series of factory tests made prior to dispatch. A screen displaying anything different indicates a fault condition, and the relay should be returned to Strike Technologies.

```
Test : LED's
(Check flashing)
Test : Input
Input = Low
```



► This screen causes every pixel of the LCD display to operate, allowing the user to identify any faults on the screen.

► This enables the user to check that the LED indicators work by checking that they flash during this test.

► This enables the user to check that the digital input is functional. When a voltage within the range 30 – 250 V ac/dc is applied to the digital input, the display should change from LOW to HIGH.



 Performing the following diagnostic test on the output relays, while the associated circuit breaker is energized may cause the circuit breaker to trip, with consequent system disruption. Therefore the greatest care should be exercised when performing this function under live conditions.

 ▶ To perform the output relay tests, press ▲ or ▼ to toggle the “No” to “Yes”, then press . To skip this test press ▶ to go to the next screen.

If Yes had been selected a screen as shown below will be displayed:
Press ◀ or ▶ to select the desired relay to test, then press ▲ or ▼ to toggle the “No” to “Yes”, followed by . The selected output relay will then energize for 1 second. Repeat for each relay.



Press ◀ or ▶ until this screen is displayed. Press ▲ or ▼ to toggle the “No” to “Yes”, followed by . The first screen in the DIAGNOSTIC TEST MENU is now displayed again.



If “No” is selected at the “Test Relays?” screen, pressing ▶ displays:

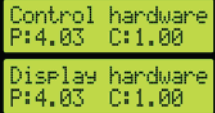

▶ The next two screens supply hardware information which may be necessary in future to ensure compatibility with firmware upgrades.

Press  to revert back to the main menu.

Injection Testing

The RLC04-B Relay is a complex device with many sophisticated protective functions. It is beyond the scope of this manual to fully detail how too comprehensively injection test the RLC04-B. However the following points should be noted.

Ideally, a 3 phase secondary injection test set, with the ability to inject not only mains frequency currents but also complex 3 phase waveforms (including harmonic currents) is required to properly test the RLC04-B.

In this way one can properly test and confirm the peak repetitive overvoltage protective functions, the rms thermal overcurrent protective functions, and the mains frequency current protective functions including the star unbalance, line unbalance, earth fault, fundamental frequency over- and under-current, breaker fail and breaker enable timer.

Such a test set is available from Strike Technologies.

It is possible to perform tests on the relay with only a single phase current injection test set. In this case the user should preferably test each element separately, one protective function at a time, with all other protective functions disabled.

If testing several protective functions and/or elements simultaneously, the following must be kept in mind:
The earth fault current I_0 is derived mathematically as the vector summation of the phase currents of elements 1, 2 and 3. Therefore the earth fault protective function should be tested by injecting 1/3 of the desired earth fault current into elements 1, 2 and 3 connected in series. This will generally avoid the other protective functions, including the line unbalance current protective function, from operating before the earth fault protective function. In order to test the line unbalance current function, inject a low magnitude single phase current into elements 1 and 2 (or elements 2 and 3) connected in series but with opposite polarities. This will avoid the earth fault protective function from operating.

In order to test the overcurrent, undercurrent and thermal current, protective functions of elements 1, 2 and 3, disable the earth fault protective function and inject a single phase current into elements 1, 2 and 3 connected in series. This will avoid both the earth fault and the line unbalance current protective functions from operating. Alternatively disable both the earth fault and the line unbalance current protection functions. This will enable elements 1, 2 and 3 to be tested individually, without all 3 elements connected in series.



Electrical Distributors

Without the ability to inject harmonic currents superimposed onto the fundamental current, the repetitive peak overvoltage protective function of element 1, 2 and 3 can be easily tested by disabling all other protective functions, and injecting a sinusoidal current into element 1, 2 or 3. It is suggested that $I_{cr}/I_n = 1$ and $V_{c>}/V_{cr} = 1,1$ should be set. In this case, when a sinusoidal current equal to I_n is injected (1A or 5A rms) then the calculated peak repetitive voltage $V_{c>}/V_{cr}$ should be 1p.u. The $V_{c>}$ starter should operate for injected currents above 1,1 I_n . Trip times for currents above the threshold (1,1 I_n) may be checked against the inverse time curve of Figure 3 in Appendix 3.

Trouble Shooting

Before attempting to trouble-shoot the equipment, the user should thoroughly understand this entire manual, and should have a prior knowledge of power system protection, power system measurements, and power system safety procedures. The user should study carefully the applicable sections of this manual, taking particular note of WARNINGS, CAUTIONS and NOTES included for personnel and equipment protection.

For trouble-shooting and commissioning, the following equipment is required:

Digital multimeter with clip-on current tong for measuring 1A or 5A current transformer secondary's.

A three or single phase primary or secondary injection test set to enable injection of the CT nominal rated secondary currents into the RLC04-B Relay measuring elements.

Due to the nature of the RLC04-B Relay, it is not recommended that the user should attempt repairs other than the removal and replacement of the draw-out unit which houses all electrical and electronic parts.

If erroneous, inconsistent or nonsensical data is displayed on the RLC04-B, or if erratic faulty operation is experienced by the user, check the various parameters set in the relay and verify that the relay is set up correctly.

If the user has performed all the above checks, and is satisfied that no external or setting-up problems exist which are causing the malfunctions experienced, then the relay should be returned to Strike Technologies together with a fault report, documenting the details of the problem experienced, the configuration & set-up, as well as installation details.

The user may elect to send only the draw-out unit without the fixed case. If so then special attention should be paid to the handling requirements, as detailed in the Installation and Commissioning section.



Electrical Distributors

Appendix 1

Table 1 - Step-By-Step Installation Instructions

- 1 Unpack the relay, and check for obvious damage.
If the contact form (normally open or normally closed) of any of output relays #1, #2, #3, #4, #5 or #6 is to
- 2 be changed from the default settings of normally open to normally closed, withdraw the draw-out module and reconfigure the appropriate contacts.
- 3 Insert the draw-out module back into the fixed casing and affix the front cover of the relay.
Mount the RLC04-B Relay within a cut-out on the switchgear or relay panel, or within an appropriate 19
- 4 inch rack. Ensure that the fixed housing is securely screwed to the panel or 19 inch rack, using the mounting holes on the fixed housing. These are accessible from the front without removing the front cover of the relay.
- 5 Wire the auxiliary power supply to the relay - do not apply voltage yet.
- 6 Wire the current transformer circuits to the relay - do not apply current to the inputs yet.
- 7 Wire the appropriate output relay circuits to suit the application - do not apply voltage yet.
- 8 If applicable, wire the digital input circuits - do not apply voltage yet.
Measure the auxiliary power supply voltage, the voltages for the output relays and the voltage for the digital
- 9 input. Confirm that these voltages are correct and within the acceptable range in accordance with the RLC04-B specifications. Only then apply these voltages to the relay. Measure the voltages at the terminals to confirm that the voltages at the relay terminals are correct. Check that with auxiliary power applied, the self-supervision relay #6 is energized and that its contacts are in the correct state.
- 10 Check that the LCD screen is showing the normal operation display, that the green POWER ON / HEALTHY LED is on, and that the yellow and red LED's are off.
- 11 Access the main menu. See Section 6 – Navigating the RLC04-B Menu for details.
- 12 Access the Hardware Setup Menu and configure the relay to suit your application (Normal Mode / H-Bridge Mode \ 50Hz / 60Hz \ Element 1-4 rated current selection).
- 13 Configure the parameter settings for the protection elements as well as the OTHER settings to suit the application.
- 14 Save the parameter settings configured.
- 15 From the main menu, access the OUTPUT RELAY SETUP function.
- 16 Configure the functionality of output relays 1,2,3,4, and 5 to suit the application.
- 17 Check that the output relay checksums are correct for the desired output relay configuration.
- 18 Save the output relay functionality configuration.
- 19 From the main menu, access the DIAGNOSTIC TEST sequence, and execute the diagnostic test. Confirm that all diagnostic tests produce satisfactory results.
- 20 From the main menu, access the SERIAL PORT options, and select the appropriate baud rate and parity (and type of backside port) for the serial ports.
- 21 Save the serial data port settings.
- 22 From the main menu, access the ACCESS AND SET REAL TIME CLOCK to the actual time and date.
- 23 Revert back to the normal running screen displays.
Perform primary or secondary injection tests. Confirm that the normal running parameters displayed are
- 24 correct, and that the protective functions are operational. Perform any other relevant commissioning checks and tests.
Once any other commissioning tests associated with the complete installation are completed, and the
- 25 associated circuit breaker is energized, check that the parameters displayed on the normal running screen are sensible and correct.
- 26 Compensate either the natural star point unbalance current, or the individual natural unbalance currents of the H-Bridge if appropriate.
- 27 Document all the commissioning tests and the RLC04-B Relay settings carefully.



Caution

T Performing any changes to element variable or other settings, changes to output relay configurations, or running the diagnostic test sequence to test the output relays may cause the associated circuit breaker to trip. This could cause serious system functions on-line, and the user should have a thorough knowledge of this entire manual as well as the particular application and system.



Table 2: Nomenclature and Definitions for Normal Mode

Symbol	Definition
I _{cr}	Capacitor rated current.
I _n	Current transformer nominal primary current
I _{cr} /I _n	Capacitor rated current per unit of current transformer nominal primary current
V _c	Calculated capacitor repetitive peak voltage
V _{cr}	Capacitor rated repetitive peak voltage
V _{c>al}	V _c alarm threshold
V _{c>al:xt}	Alarm time-out setting for the V _c timer
V _{c>alarm}	Software signal indicating that V _c has exceed V _{c>al} for the time V _{c>al:xt} set
V _{c>}	V _c low-set overvoltage threshold.
V _{c>start}	Software signal indicating that V _c has exceeded V _{c>} , and that the inverse timer is running
V _{c>trip}	Software signal indicating that V _c has exceeded V _{c>} and the inverse timer has timed out
V _{c>reset}	Time-out setting for the V _{c>} /V _{cr} reset timer
V _{c>>}	V _c high-set overvoltage threshold
V _{c>>:xt}	High-set time-out setting for the V _c timer
V _{c>>trip}	Software signal indicating that V _c has exceeded V _{c>>} for the time V _{c>>:xt} set
I _{rms}	The calculated rms heating current
I _{rms>}	I _{rms} low-set overcurrent threshold
I _{rms>:xt}	Low-set time-out setting for the I _{rms} timer
I _{rms>start}	Software signal indicating that I _{rms} has exceeded I _{rms>} , and that the I _{rms} timer is running
I _{rms>trip}	Software signal indicating that I _{rms} has exceeded I _{rms>} for the time I _{rms>:xt} set
I _{rms>>}	I _{rms} high-set overcurrent threshold
I _{rms>>:xt}	High-set time-out setting for the I _{rms} timer
I _{rms>>trip}	Software signal indicating that I _{rms} has exceeded I _{rms>>} for the time I _{rms>>:xt} set
τ	Heating / cooling time constant
I _{th}	Calculated thermal current response to I _{rms}
I _{th>al}	I _{th} alarm threshold
I _{th>alarm}	Software signal indicating that I _{th} has exceeded the alarm threshold
I _{th>}	I _{th} low-set overcurrent threshold
I _{th>:xt}	Low-set time-out setting for I _{th} timer
I _{th>start}	Software signal indicating that I _{rms} has exceeded I _{th>} threshold
I _{th>trip}	Software signal indicating that I _{th} has exceeded I _{th>} for the time I _{th>:xt} set
I _{th>>}	I _{th} high-set overcurrent threshold
I _{th>>:xt}	High-set time-out setting for I _{th} timer
I _{th>>trip}	Software signal indicating that I _{th} has exceeded I _{th>>} for the time I _{th>>:xt} set
I ₁	Calculated fundamental frequency current
I _{1<}	I ₁ undercurrent threshold
I _{1<:xt}	Undercurrent time-out setting for the I ₁ timer
I _{1<trip}	Software signal indicating that I ₁ has dropped below I _{1<} for the time I _{1<:xt} set, while the digital input was in the Active state
I _{1>}	I ₁ low-set overcurrent threshold
I _{1>:xt}	Low-set time-out setting for the I ₁ timer
I _{1>start}	Software signal indicating that I ₁ has exceeded I _{1>} , and that the I ₁ timer is running
I _{1>trip}	Software signal indicating that I ₁ has exceeded I _{1>} for the time I _{1>:xt} set
I _{1>>}	I ₁ high-set overcurrent threshold
I _{1>>:xt}	High-set time-out setting for the I ₁ timer
I _{1>> trip}	Software signal indicating that I ₁ has exceeded I _{1>>} for the time I _{1>>:xt} set
I _{ub}	Calculated uncompensated fundamental frequency star point unbalance current
ΔI_{ub}	Compensated fundamental frequency rms star point unbalance current, i.e. the change in fundamental frequency rms current from that at the instant of compensation
I _{ub_al}	I _{ub} alarm current threshold



Electrical Distributors

lub_al:xt	Alarm time-out setting for lub
lub_alarm	Software signal indicating that lub has exceeded lub_al for the time lub_al:xt set
lub>	lub low-set overcurrent threshold
lub>:xt	Low-set time-out setting for the lub timer
lub>start	Software signal indicating that (Δ)lub has exceeded lub> and the lub timer is running
lub>trip	Software signal indicating that (Δ)lub has exceeded lub> for the time lub>:xt set
lub>>	lub high-set overcurrent threshold
lub>>:xt	High-set time-out setting for the lub timer
lub>>trip	Software signal indicating that (Δ)lub has exceeded lub>> for the time lub>>:xt set
llub	Calculated fundamental frequency line unbalance current
llub>	llub low-set overcurrent threshold
llub>:xt	Low-set time-out setting for the llub timer
llub>start	Software signal indicating that llub has exceeded llub>, and that the llub timer is running
llub>trip	Software signal indicating that llub has exceeded llub> for the time llub>:xt set
llub>>	llub high-set overcurrent threshold
llub>>:xt	High-set time-out setting for the llub timer
llub>>trip	Software signal indicating that llub has exceeded llub>> for the time llub>>:xt set
lo	Calculated fundamental frequency earth fault current
lo>	lo low-set overcurrent threshold
lo>:xt	Low-set time-out setting for the lo timer
lo>start	Software signal indicating that lo has exceeded lo>, and that the lo timer is running
lo>trip	Software signal indicating that lo has exceeded lo> for the time lo>:xt set
lo>>	lo high-set overcurrent threshold
lo>>:xt	High-set time-out setting for the lo timer
lo>>trip	Software signal indicating that lo has exceeded lo>> for the time lo>>:xt set
Bon	Input signal indicating that the circuit breaker of the capacitor bank / harmonic filter circuit is on
Bfail1	Signal indicating that when a trip occurred, the Bfail1 release function had not been fulfilled within the Bfail1:xt time, indicating a failure of the circuit breaker to open
Bfail1 release	The function which stops the Bfail1 timer, selectable from: Ifund<10%In; Dig-Input (logic "1" to "0"); Ifund AND Input; Ifund OR Input
Bfail1:xt	Time-out setting associated with Bfail1 logic
Bfail2	Software signal indicating that the fundamental frequency current remained above the undercurrent threshold for the Bfail2:xt time, while the digital input (Breaker-Bon) signalled a switching off (logic "1" to "0") - indicating the failure of the circuit breaker to interrupt the capacitor bank / harmonic filter circuit current.
Bfail2:xt	Time-out setting associated with Bfail2 logic
Bena	Software signal that can be used to inhibit the re-energizing of the banks' circuit breaker for a definite time after the Bena trigger signal has become active. Bena output signal (Breaker inhibit) is normally at logic "0" (low) and goes to logic "1" (high) when the bank is switched off, and reverts to logic "0" (low) the definite time Bena:xt thereafter.
Bena:xt	Timer setting associated with the Bena logic
Trip session	A trip session starts from the first active trip condition until the last trip condition has been cleared. The visible observation of this session is defined by the time when the trip LED lights up to the time when the alarm LED goes off. During this time ▲ or ▼ may be used to scroll between the different trip messages. ■ may be used to acknowledge trips for which the cause of the trip has fallen below the trip threshold. In case of an lth trip, the trip can be acknowledged as soon as the Irms has fallen below the lth trip threshold, however the trip output function will only be reset once lth has fallen below the lth trip threshold



Electrical Distributors

Table 3: Nomenclature & Definitions for H-Bridge Mode

Symbol	Definition
1/2/3/4	Element 1/2/3/4
I_n	Current transformer nominal primary current.
a/b/club	Calculated uncompensated fundamental frequency a/b/c-phase unbalance current
a/b/club_al/ I_n	a/b/club alarm threshold per unit of I_n
a/b/club_al:xt	Alarm time-out setting for the a/b/club timer
a/b/club_alarm	Software signal indicating that a/b/club has exceeded a/b/club_al for the time a/b/club_al:xt set
a/b/club>/ I_n	a/b/club low-set threshold per unit of I_n
a/b/club>:xt	Low-set time-out setting for the a/b/club timer
a/b/club>start	Software signal indicating that (Δ)a/b/club has exceeded a/b/club>, and that the a/b/club timer is running
a/b/club>trip	Software signal indicating that (Δ)a/b/club has exceeded a/b/club> for the time a/b/club>:xt set
a/b/club>>/ I_n	a/b/club high-set threshold per unit of I_n
a/b/club>>:xt	High-set time-out setting for the a/b/club timer
a/b/club>>trip	Software signal indicating that (Δ)a/b/club has exceeded a/b/club>> for the time a/b/club>>:xt set
Δ a/b/club	Compensated fundamental frequency rms a/b/c -phase unbalance current, i.e. the change in fundamental frequency rms current from that at the instant of compensation



Electrical Distributors

Table 4: General Characteristics

Applicable standard	IEC 60255
Operating temperature	-10 to +55 °C to IEC 60068-2-2
Storage temperature range	-20 to +70 °C to IEC 60068-2-2
Humidity	4 days, 95% RH, with temperature cycled between +25°C and + 45°C, to IEC 60068-2-3
Enclosure degree of protection	IP50 to IEC 600529
Shock and bump	Shock: 15g, 3 pulses per direction, per axis. (total 18 times).
	Bump: 10g, 1000 pulses per direction, per axis (total 6000 times). To IEC 60255-21-2
Vibration	9, 8ms ⁻² (1g) constant frequency from 10 to 500 Hz per axis. To IEC 60255-21-1 2 kV rms 50 Hz for 1 minute, from all terminals to case (earth), and between terminals of independent circuits.
Power frequency voltage withstand	1.5 kV rms across open contacts of output relays. To IEC 60255-5
Impulse voltage withstand	5 kV peak, 1.2/50 µs waveshape, 0.5 J energy content, 10 shots in each polarity, between all terminals and case (earth), and between terminals of independent circuits. To IEC 60255-5
Insulation resistance	50 MΩ minimum at 500 V dc, to IEC 60255-5
Immunity to high frequency disturbances (1MHz burst disturbance test)	2.5 kV peak between independent circuits, and to case (earth).
	1 kV peak across terminals of the same circuit. To IEC 60255-22-1
Immunity to electrostatic discharges (Electrostatic discharge test)	8 kV discharge in air with cover in place.
	4 kV point contact discharge with cover removed. To IEC 60255-22-2 and EN 50082-2
Immunity to fast transient bursts (Fast transient burst test)	Class 4 (4 kV). To IEC 60255-22-4 and EN 50082-2
Immunity to high frequency electromagnetic fields	10 V / m from 27 to 500MHz, to IEC 60255-22-3
	10 V, 80% AM, from 150 to 80 MHz as well as
	10 V / m, 80% AM, from 80 to 1000 MHz, to EN 50082-2
Conducted disturbances induced by radio-frequency fields immunity test	To EN 50081
Immunity to high frequency electromagnetic field (Pulse modulated, simulation of the effect of cell phones)	To ENV 50204
Conducted emissions	To EN 50081-2, from 150 kHz to 30 MHz.
Radiated emissions	To EN 50081-2, from 30 kHz to 1000 MHz.
Nett Mass	3 kg
Overall dimensions	103(w) x 177(h) x 248(d)



The power supply inputs of the RLC04-B are protected by MOV's. Therefore it is not possible to perform the power frequency and the impulse voltage withstand test on these terminals on the commercial unit without causing damage!



Electrical Distributors

Table 5: Technical Specifications

Measuring elements	Quantity	4
	Nominal rated current, In	1A or 5A selectable in the software
Auxiliary power supply	Continuous current	15A
	Short time current	300A for 1s
	Burden	<40mΩ
	Accuracy of measurement	+/- 2% of nominal rated current
	Nominal rated voltage, Vx	30 – 250V ac/dc
Output relays	Operative range AC / DC	40 - 250V AC / 30 - 300V DC
	Burden with dc supply	<14W with all relays and back-light ON
	Burden with ac supply	<24VA with all relays and back-light ON
K1	Quantity	Alarm/trip relays: 5 Self-supervision relay: 1
	Contact form (per relay)	1 changeover contact (form C), user configurable as N/O or N/C
K2, K3, K4, K5, K6	Load	Resistive load: Inductive load: (cos φ = 1) (cos φ = 0,4 L/R = 7 ms)
	Rated load	5A at 250 VAC: 3,5A at 250 VAC: 1A at 220 VDC 0,8A at 220 VDC 3A at 110 VDC 2A at 110 VDC 5A at 48 VDC 4A at 48 VDC
Digital input channel	Max. operating voltage	380VAC, 250 VDC
	Rated load	5A at 250 VAC: 3,5A at 250 VAC: 5A at 30 VDC 2,5A at 30 VDC
	Rated carry current	5A
Pushbuttons	Max. operating voltage	380VAC, 125 VDC
	Min. permissible load	100mA at 5 VDC
Display	Quantity	1
	Function	Breaker on; Remote reset; Event trip
Indicators	Isolation	Optically isolated
	Type	30 – 250V ac/dc voltage input
Serial data ports	Function	◀, ▶, ▲, ▼, and  (accept)
	Type	Miniature spring loaded manual pushbuttons
Real Time Clock	Display	Back-lit Liquid Crystal Display (LCD), with full alpha-numeric character set
	Screen Size	16 character x 2 line
Serial data ports	Character height	4mm
	Type	Light Emitting Diodes (LED's)
Real Time Clock	Function	Green : POWER ON / HEALTHY Yellow : START Red : TRIP
	Quantity	2
Serial data ports	Isolation	Optically isolated
	Front port type	RS232 via DB9 socket
Real Time Clock	Rear port type	RS232 or RS485 – selectable in the software
	Baudrate (kBd)	2.4 - to 115.2 for each port separately selectable
Real Time Clock	Functionality	Date; Weekday; hh:mm:ss
	Accuracy	+/- 30s per month
Real Time Clock	Backup	Supercap (>14 days without power)



Electrical Distributors

Table 6: Settable Parameters and Ranges – Normal Mode

Parameter	Setting Range	Resolution	Preset Value
Icr/In	0,25 to 1,50	0,01	1,00
vc>al/vcr	0,80 to 1,50 // N/A	0,01	N/A
vc>al:xt	0,1 to 3600 s	0,1 s	0,1 s
vc>/vcr	0,80 to 1,50 // N/A	0,01	N/A
vc>>/vcr	0,80 to 10,0 // N/A	0,01	N/A
vc>>:xt	0,03 to 10,0 s	0,01 s	0,03 s
vc>reset:xt	1 s to 3600 s	1 s	1 s
Ith>/In	0,25 to 1,50 // N/A	0,01	N/A
Ith>:xt	0 to 600 s // Alarm	0,01s	0,0 s
Ith>>/In	0,25 to 1,50 // N/A	0,01	N/A
Ith>>:xt	0 to 60 s	0,01 s	0,0 s
τ	0,5 to 7200 s	0,1 s	0,5 s
I1>/In	0,25 to 1,50 // N/A	0,01	N/A
I1>:xt	0,1 to 1200 s	0,1 s	0,1 s
I1>>/In	0,2 to 10,0 // N/A	0,1	N/A
I1>>:xt	0,05 to 10,0 s	0,01 s	0,05 s
I1</In	0,05 to 1,00 // N/A	0,01	N/A
I1<:xt	0,1 to 10,0 s	0,1 s	0,1 s
Irms>/In	0,25 to 1,50 // N/A	0,01	N/A
Irms>:xt	0,1 to 1200 s	0,1 s	0,1 s
Irms>>/In	0,2 to 10,0 // N/A	0,1	N/A
Irms>>:xt	0,03 to 10,0 s	0,01s	0,03 s
Iub_al/In	0,01 to 2,00 // N/A	0,01	N/A
Iub_al:xt	0,1 to 600 s	0,1s	0,1 s
Iub>/In	0,01 to 2,00 // N/A	0,01	N/A
Iub>:xt	0,1 s to 14400 s	0,1 s	0,1 s
Iub>>/In	0,01 to 2,00 // N/A	0,01	N/A
Iub>>:xt	0,05 to 60 s	0,01 s	0,05 s
Ilo>/In	0,05 to 1,00 // N/A	0,01	N/A
Ilo>:xt	0,1 to 60 s	0,01 s	0,1 s
Ilo>>/In	0,05 to 10,0 // N/A	0,01	N/A
Ilo>>:xt	0,05 to 10,0 s	0,01 s	0,05 s
Ilub>/In	0,01 to 1,00 // N/A	0,01	N/A
Ilub>:xt	0,1 to 60 s	0,1 s	0,1 s
Ilub>>/In	0,01 to 1,00 // N/A	0,01	N/A
Ilub>>:xt	0,05 to 10,0 s	0,01 s	0,05 s
Function of Digital Input	Breaker-Bon // Remote Reset // Event Trip // Disabled		Disabled
Event:xt	0,03 to 600 s	0,01 s	0,03 s
Bfail1:xt	0,01 to 2,0 s // N/A	0,01 s	N/A
Bfail1 released:	Ifund<10%In // Dig-Input // Ifund AND Input // Ifund OR Input		Ifund<10%In
Bfail2:xt	0,01 to 2,0 s // N/A	0,01 s	N/A
Bena:xt	1 to 1200 s // N/A	1 s	N/A
Bena trigger by:	Ifund<10%In // Dig-Input // Ifund AND Input // Ifund OR Input		Ifund<10%In
Start LED shows:	Only trip STARTS // Only ALARMS // STARTS + ALARMS // Always off		STARTS + ALARMS



Electrical Distributors

Table 7 – Settable Parameters and Ranges – H-Bridge Mode

Parameter	Setting Range	Resolution	Preset Values
aIub_al/In	0,01 to 2,00 // N/A	0,01	N/A
aIub_al:xt	0,1 to 600 s	0,1 s	0,1 s
aIub>/In	0,01 to 2,00 // N/A	0,01	N/A
aIub>:xt	1 s to 240 min	1 s	1 s
aIub>>/In	0,05 to 2,00 // N/A	0,01	N/A
aIub>>:xt	0,0 to 60 s	0,1 s	0,1 s
bIub_al/In	0,01 to 2,00 // N/A	0,01	0,01
bIub_al:xt	0,1 to 600 s	0,1 s	0,1 s
bIub>/In	0,01 to 2,00 // N/A	0,01	0,01
bIub>:xt	1 s to 240 min	1 s	1 s
bIub>>/In	0,05 to 2,00 // N/A	0,01	0,01
bIub>>:xt	0,0 to 60 s	0,1 s	0,1 s
cIub_al/In	0,01 to 2,00 // N/A	0,01	N/A
cIub_al:xt	0,1 to 600 s	0,1 s	0,1 s
cIub>/In	0,01 to 2,00 // N/A	0,01	N/A
cIub>:xt	1 s to 240 min	1 s	1 s
cIub>>/In	0,05 to 2,00 // N/A	0,01	N/A
cIub>>:xt	0,0 to 60 s	0,1 s	0,1 s
Function of Digital Input	Remote Reset // Event Trip // Disabled		Disabled
Event:xt	0,03 to 600 s	0,01 s	0,03 s
Start LED shows:	Only trip STARTS // Only ALARMS // STARTS + ALARMS // Always off		STARTS + ALARMS



Appendix 2

Example 1: Calculation of Checksums for Output Relays 1 To 5

During an unhealthy system condition the RLC04-B can generate any of a number of software signals, each of which can be allocated to one or more output relays. For each function routed to a relay, the relative bit in the checksum table below must be set to a binary 1, for each function not routed to a relay the bit must be cleared to 0.

This results in a 30 digit binary code, for each output relay in Normal Mode, which is difficult for the user to interpret. By representing this string in hexadecimal code (hex code), where up to four binary digits are converted to one hex digit, the above binary string is converted to a unique 8 digit hex code, representing all the allocations to that output relay. The four digits represent the decimal values 8,4, 2 and 1.

Example: Binary 1010 = (1 * 8) + (0 * 4) + (1 * 2) + (0 * 1) = 10 Decimal = A Hex

The result can be decimal values between 0 and 15. As the hex digit must be a single digit, the characters A...F are used to represent the decimal values 10...15, as shown here:

Dec.	Hex	Binary	Dec.	Hex	Binary	Dec.	Hex	Binary	Dec.	Hex	Binary
15	F	1111	11	B	1011	7	7	0111	3	3	0011
14	E	1110	10	A	1010	6	6	0110	2	2	0010
14	D	1101	9	9	1001	5	5	0101	1	1	0001
12	C	1100	8	8	1000	4	4	0100	0	0	0000

Typical Examples of Output Relay Settings and Resulting Checksums

One of 5 Output Relays in Normal Mode Operation

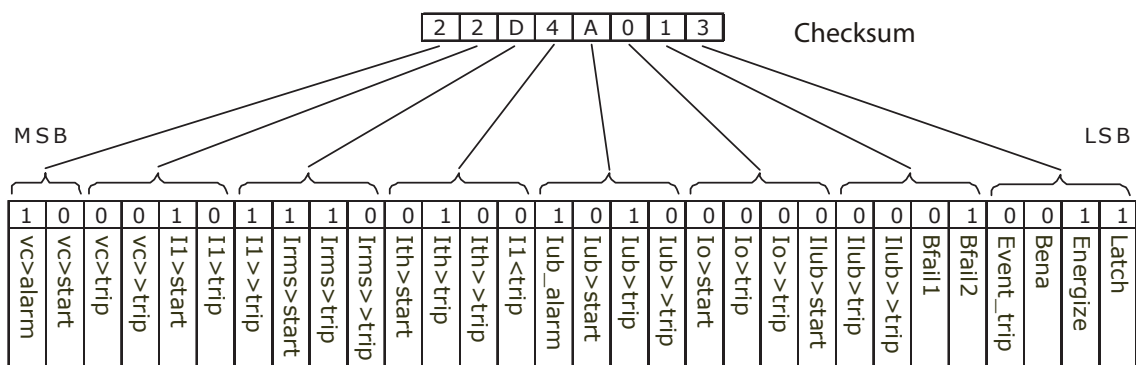

One of 5 Output Relays in H-Bridge Mode

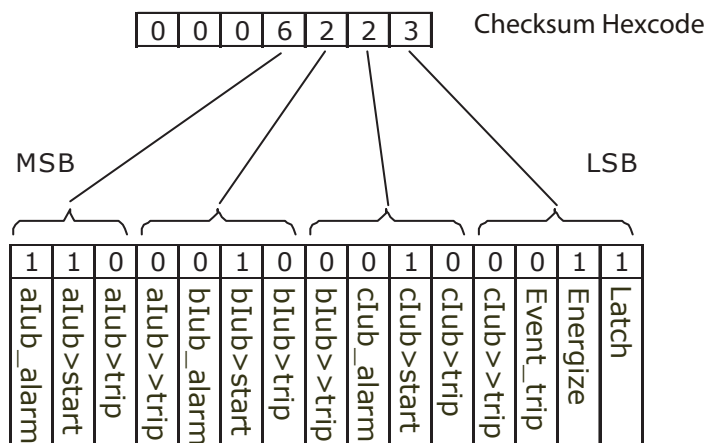



Electrical Distributors

Example 2: RLC04-B Setting Calculations

20 Mvar harmonic filter with a double star capacitor bank

System	33 kV + 5%, 3 phase, 50 Hz, 20 kA fault level		
Earthing	Solidly earthed		
Switch	630 A SF6 circuit breaker		
Line CT's	500 / 5 A		
Cable	185 mm ² XLPE		
Filter	Output at 33 kV 50 Hz:	20 Mvar (lead)	
Filter reactors	Inductance:	20,6 mH per phase	

Rated Currents	I1	385A	I5	30 A
	I2	30A	I7	20 A
	I3	90A	I11	10 A
	I4	25A	I13	5 A

$$I_{rms} = \sqrt{\sum_{n=1}^{13} I_n^2} \quad (= 400A)$$

Double star configuration
 Rated output: 37.193 Mvar
 Rated voltage and frequency: 45 kV 50 Hz

Capacitor bank
 Rated current $I_{cr} = 37.193 \cdot 10^6 / (\sqrt{3} \cdot 45000) = 477A$

I1 at 33 kV = $20 \cdot 10^6 / (\sqrt{3} \cdot 33000) = 350A$

Star point unbalance alarm current: 4 A – 3 s
 Star point unbalance low set trip current: 8 A – 10 min
 Star point unbalance high set trip current: 12 A - 1s

Unbalance CT
 20 / 1 A

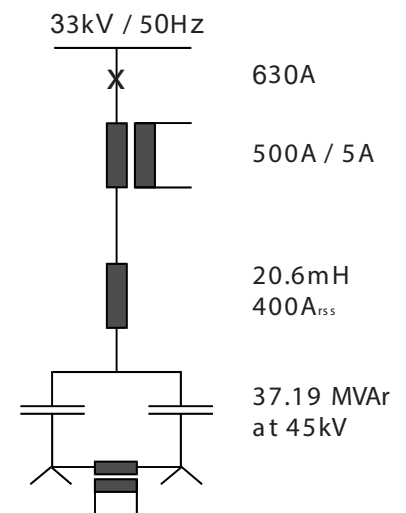



Settings

Element 1, 2, 3 variables			
lcr/ln	=	$477/500=0,95$	(1)
vc>/vcr	=	1,1	(2)
vc>>/vcr	=	3,0	(3)
vc>>:xt	=	0 s	(4)
vc>reset:xt	=	30 s	(5)
lth>/ln	=	$395/500=0,79$	(6)
lth>:xt	=	N/A	(7)
lth>>/ln	=	$410/500 = 0,82$	(8)
lth>>:xt	=	0 s	(9)
t	=	1200 s	(10)
l1>/ln	=	$1,075 \cdot 350/500=0,81$	(11)
l1>:xt	=	600 s	(12)
l1>>/ln	=	$1,5 \cdot 350/500=1,05$	(13)
l1>>:xt	=	0 s	(14)
l1</ln	=	$0,2 \cdot 350/500=0,14$	(15)
l1<:xt	=	0,2 s	(16)
Other variables			
Bfail1:xt	=	0,2 s	(17)
Bfail2:xt	=	0,1 s	(17)
Bena:xt	=	600 s	(18)
Function selected for digital input:		Breaker-Bon	(19)
Bena triggered by		Dig Input	(20)
Element 4 variables			
lub_al/ln	=	$4/20=0,2$	(21)
lub_al:xt	=	3	(22)
lub>/ln	=	$8/20=0,4$	(23)
lub>:xt	=	10 min	(24)
lub>>/ln	=	$12/20=0,6$	(25)
lub>>:xt	=	1 s	(26)
Element 5 variables			
lo>/ln	=	$0,2 \cdot 350/500=0,14$	(27)
lo>:xt	=	0,1 s	(28)
lo>>/ln	=	N/A	(29)
lo>>:xt	=	0 s	(30)
llub>/ln	=	$0,05 \cdot 350/500=0,04$	(31)
llub>:xt	=	2 s	(32)
llub>>/ln	=	$0,1 \cdot 350/500=0,07$	(33)
llub>>:xt	=	0,2 s	(34)

Notes on Settings

1. Capacitor rated current in p.u. of line CT primary current.
2. Capacitors made to IEC can withstand 110% of rated voltage for extended periods of time.
3. With reference to Figure 3 in Appendix 3, it can be seen that for vc/vcr greater than 3,0 the peak repetitive overvoltage withstand curve is undefined and therefore for capacitor overvoltages above this value it is considered necessary to trip with a definite time delay.
4. The time delay should be set as low as possible, preferably with no intentional delay.
5. Refer to the figure under Programmable vc>reset Timer in the Functional Description section to see the effect of vc>reset:xt.
6. The low set thermal trip threshold is set in this case slightly below the continuous current rating, as it is assumed that the total current includes some safety margins.
7. The associated timer is set to N/A (disabled) which means that only the lth>start signal will be generated in case of an overload and no subsequent trip signal lth>trip is output.
8. The high set thermal overcurrent threshold is set slightly above the max. continuous rms current rating of the reactor. If this is exceeded the bank must be disconnected.
9. The associated definite time delay is set to 0 (no intentional delay).



Electrical Distributors

10. Refer to Example 3 in Appendix 2 for some guidance of the heating/cooling time constant of air-core filter reactors. The time constant is the time taken for the reactors to reach 63% of their final temperature, for a step change in current from 0 to 100%.
11. For a system having a maximum system voltage of 105% of nominal, a low set fundamental frequency overvoltage/overcurrent limit of 107,5% is considered appropriate. Above this value the associated definite timer will start timing out.
12. A value of 600s for this definite timer is considered appropriate to allow any automatic tap-changers to operate in the case of extended fundamental frequency system overvoltages (which in time causes fundamental frequency overcurrents in the capacitor/filter circuit).
13. A fundamental frequency overcurrent above 150% of nominal would indicate a catastrophic failure of some kind requiring immediate tripping.
14. Therefore the associated definite time delay is set to 0 (no intentional delay).
15. Any undercurrent threshold significantly below nominal current is appropriate.
16. The undercurrent definite timer is set as 0,2s or any appropriate low value to avoid spurious trip outs.
17. The breaker fail timer is set as 0,2s for Bfail1 and 0,1s for Bfail2 or any appropriate low value to avoid spurious breaker fail signal output.
18. The breaker enable timer is set to enable breaker re-energization 600s (10min) after de-energization to allow the capacitor to discharge before switching on again.
19. Setting the digital input to Breaker-Bon allows the breaker enable re-switching timer and the undercurrent protection function to be used.
20. This parameter is set to Dig In so that the Bena function is triggered by the digital input.
21. The star point unbalance alarm level is to be provided by the capacitor unit and bank designer / manufacturer as it is determined by the specific capacitor unit and capacitor bank design.
22. The definite timer associated with the above should be set to a reasonable value to avoid spurious alarms due to inrush or other short time operating conditions.
23. The star point unbalance low set trip current is to be provided by the capacitor unit and bank designer/manufacturer.
24. The definite timer associated with the above is set as 10 min as informed by the capacitor unit / bank manufacturer.
25. The star point unbalance high set trip current is to be provided by the capacitor unit and bank designer / manufacturer.
26. The definite timer associated with the above is set as 1 s as informed by the capacitor unit / bank manufacturer. In addition, this timer should not be set less than 1s due to the response time of the calculation



Electrical Distributors

of the phase angle of the unbalance current, if the phase angle of this unbalance current is of interest to the user after a trip out.

27. The fundamental frequency earth fault threshold is set to any suitably low value below the expected earth fault current (as limited by the system and earth fault zero sequence impedance).
28. The definite time delay is set to 0,1 (no intentional delay).
29. Because the low set earth fault threshold definite time delay is set to 0,1 the high-set threshold is disabled.
30. Because the high-set threshold is disabled, the timer setting is irrelevant.
31. The low-set line unbalance current threshold should be set as low as possible whilst avoiding spurious trip outs due to normal system line voltage unbalance. A line unbalance current of 5% of nominal capacitor current is considered suitable.
32. The definite timer associated with the above is set at 2s to avoid trip out on short term unbalance disturbances.
33. The high-set line unbalance current threshold is set as 10% of nominal capacitor current.
34. The definite time associated with the above is set as 0,2s

Example 3: Calculation of the Reactor Heating and Cooling Time Constant (τ)

The correct heating and cooling time constant of a damping or filter reactor should normally be obtained from the reactor manufacturer.

CALCULATIONS: FILTER REACTOR heating/cooling time constant

The formula below is considered accurate for reactor coils manufactured by Trench Austria (GmbH), but may give default results in the absence of any other information.

$$\tau = C1 * m / A$$

Where:

C1	Constant of convection and radiation and heat capacity C1=100 for single layer coils C1 = 76 for multi layer coils	
m	Mass of winding (Aluminium and insulation)	[kg]
A	Surface for convection and radiation	[m ²]

For single – layer coil : $A = (D1 + D2) * Hw * \Pi$

For double – layer coil : $A = \frac{+ 2}{2} * \frac{D}{\Pi} * Hw * 2,5 * \frac{D}{2}$

For n – layer coil : $A = \frac{+ 2}{2} * \frac{D}{\Pi} * Hw * n * \frac{D}{2}$

D1	Inner diameter [m]
D2	Outer diameter [m]
Hw	Winding height [m]

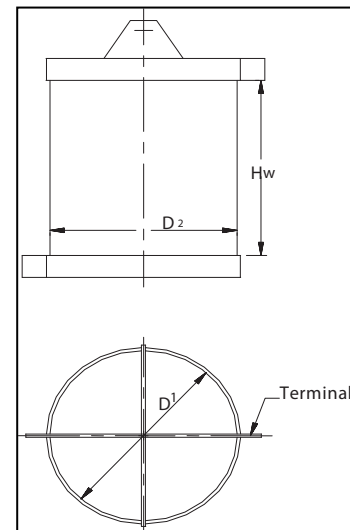

Appendix 3

Figure 1: Relay Case and Panel Cut-out Dimensions

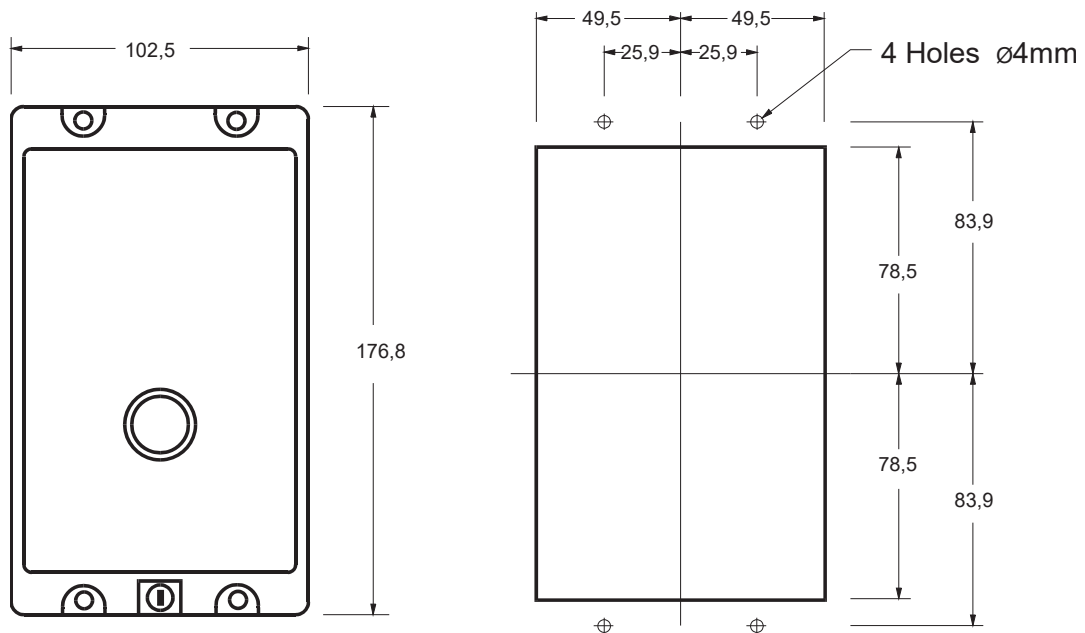

Front view

Panel cutout
159(h) x 101(w)

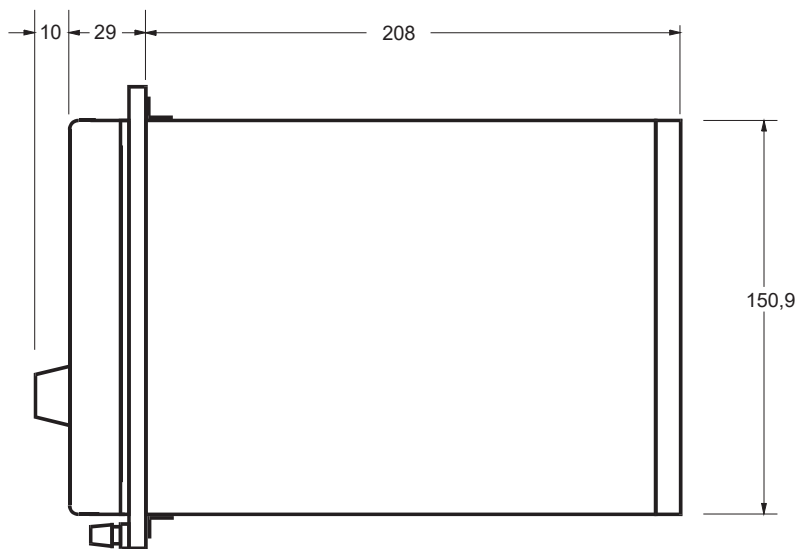

Side view

Figure 2: Schematic Diagram and Terminal Numbering

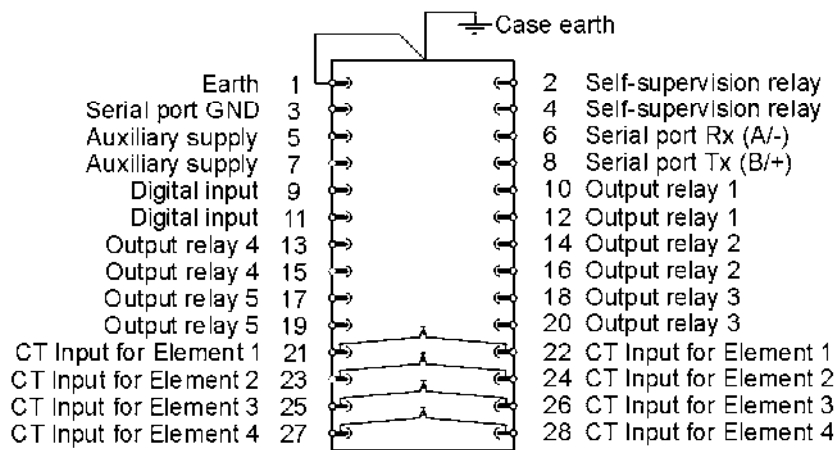
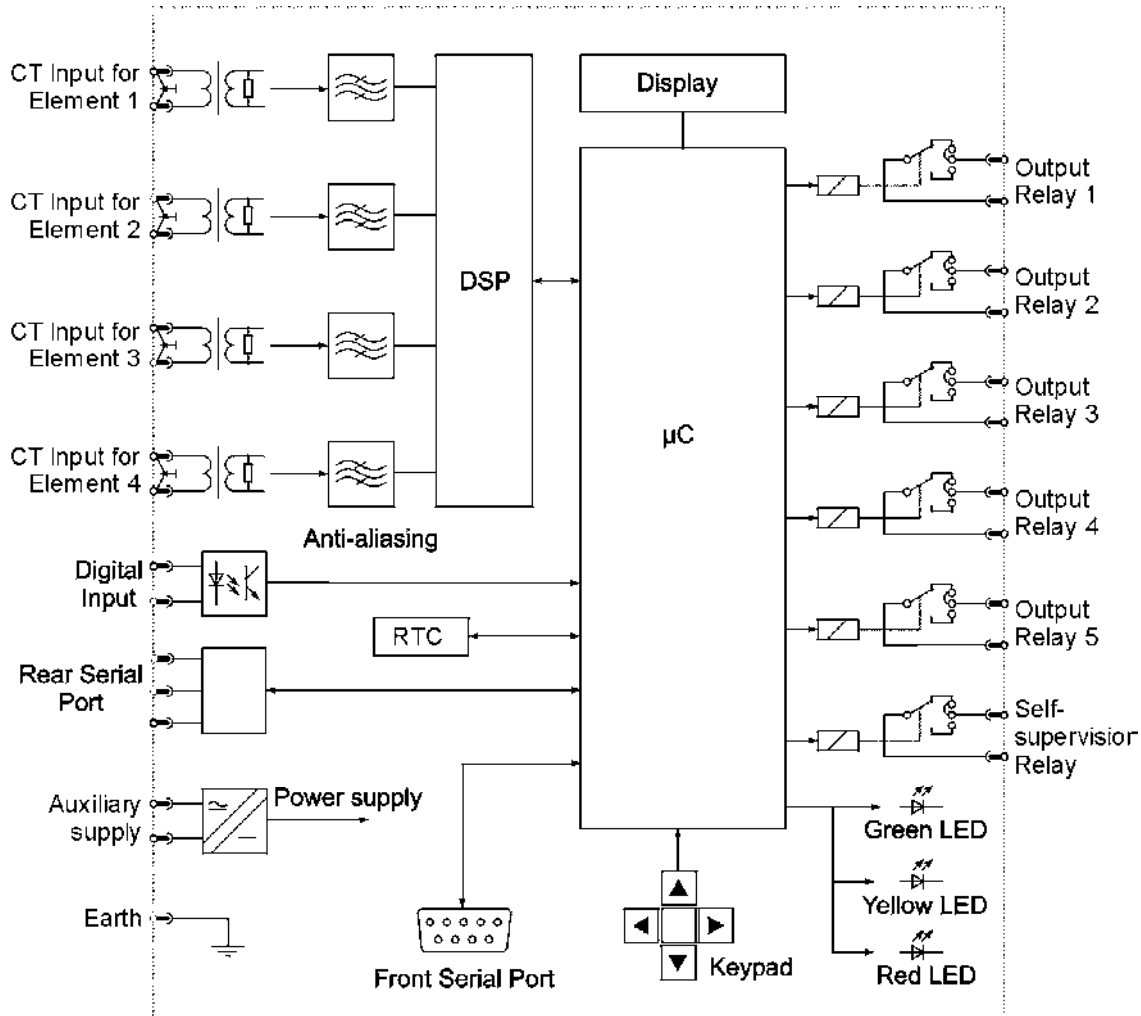

Terminal Block Viewed from Rear

Figure 3: Repetitive Peak Overvoltage vs. Trip Time Curves

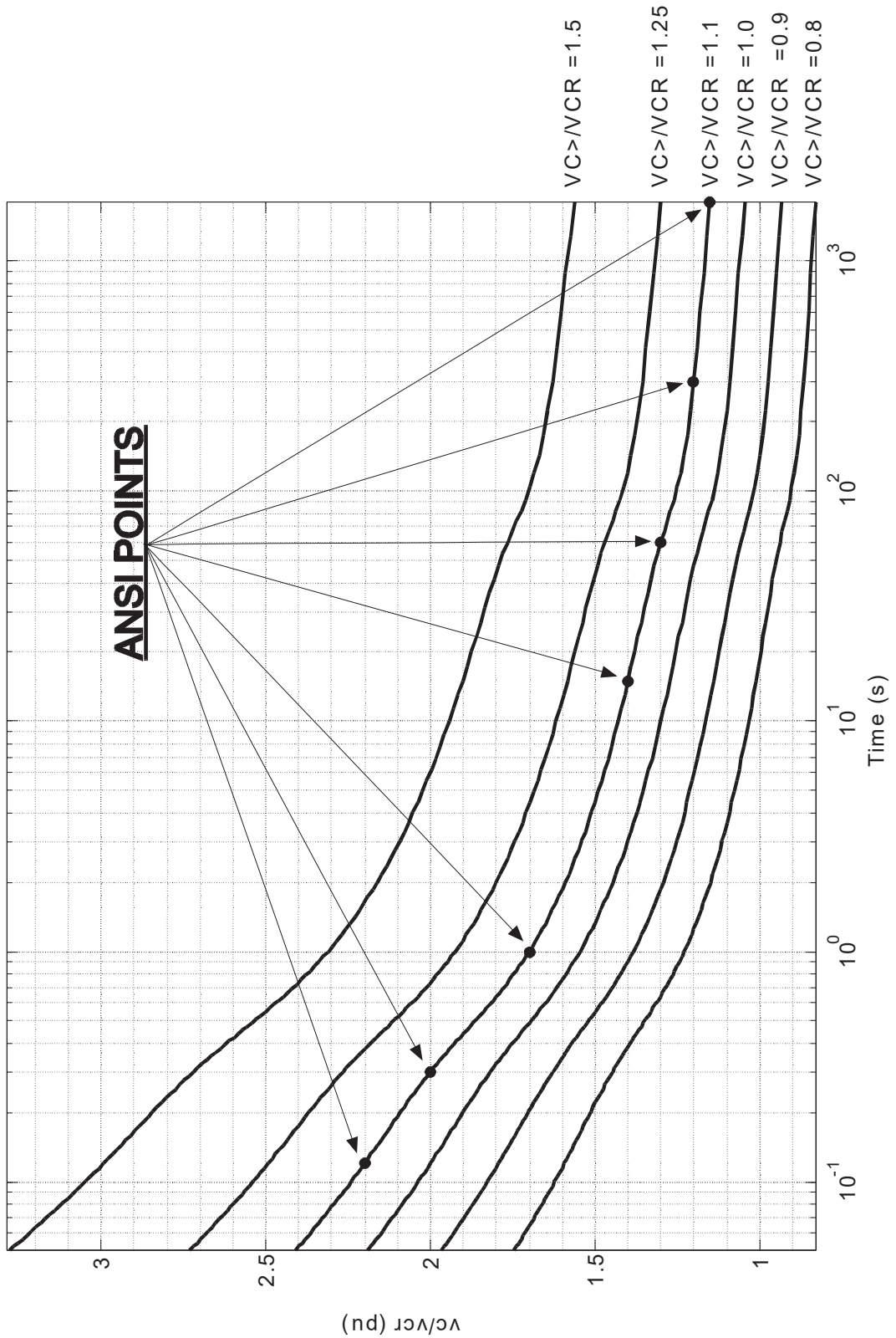



Electrical Distributors

Figure 4: Thermal Trip Time Curves
For various prior thermal loading conditions

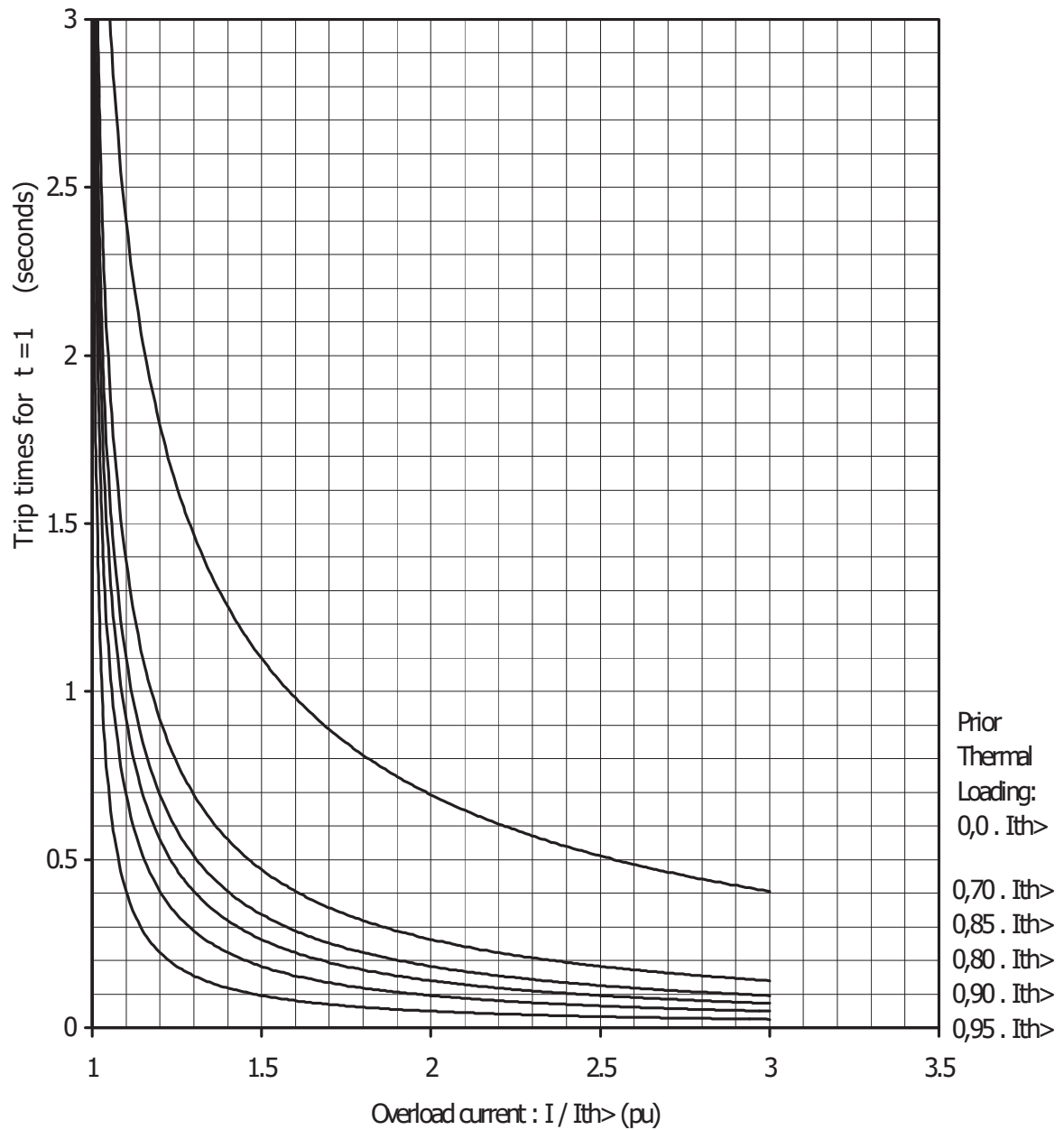
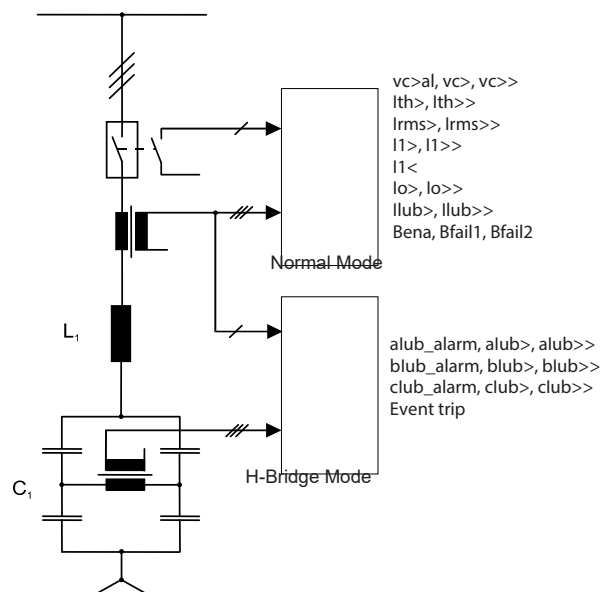
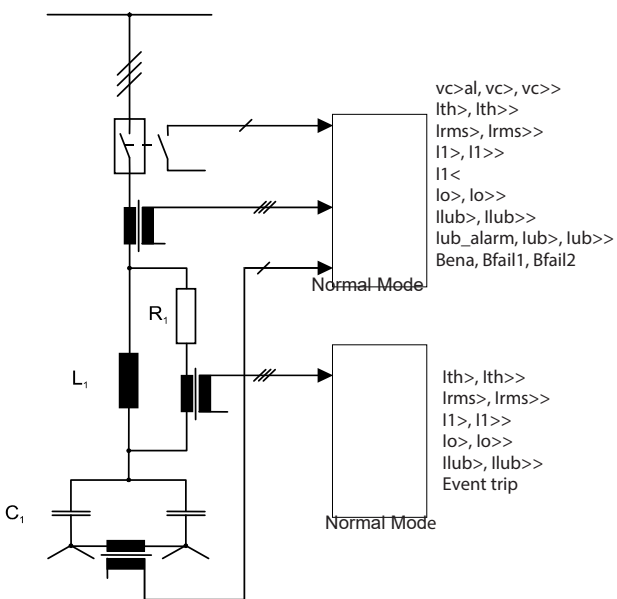
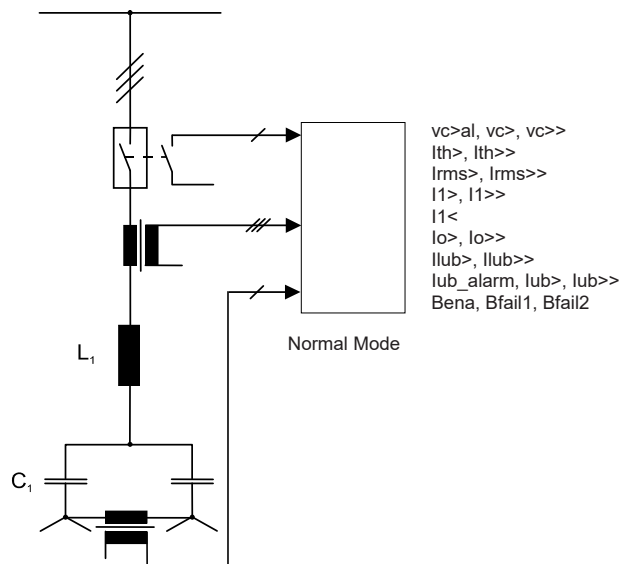
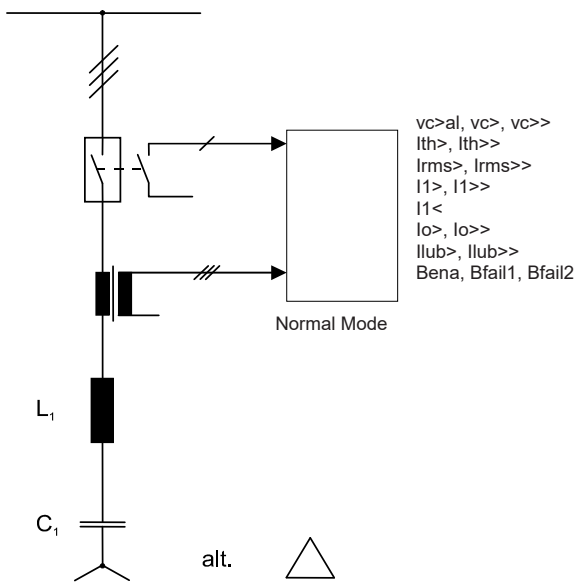

Figure 5: Typical Application Examples



Legend:

L₁ = Filter or Damping Reactor

C₁ = Capacitor Bank

R₁ = Damping Resistor



Electrical Distributors

Figure 6: Typical Wiring Diagram For A Double Star Capacitor / Filter Bank

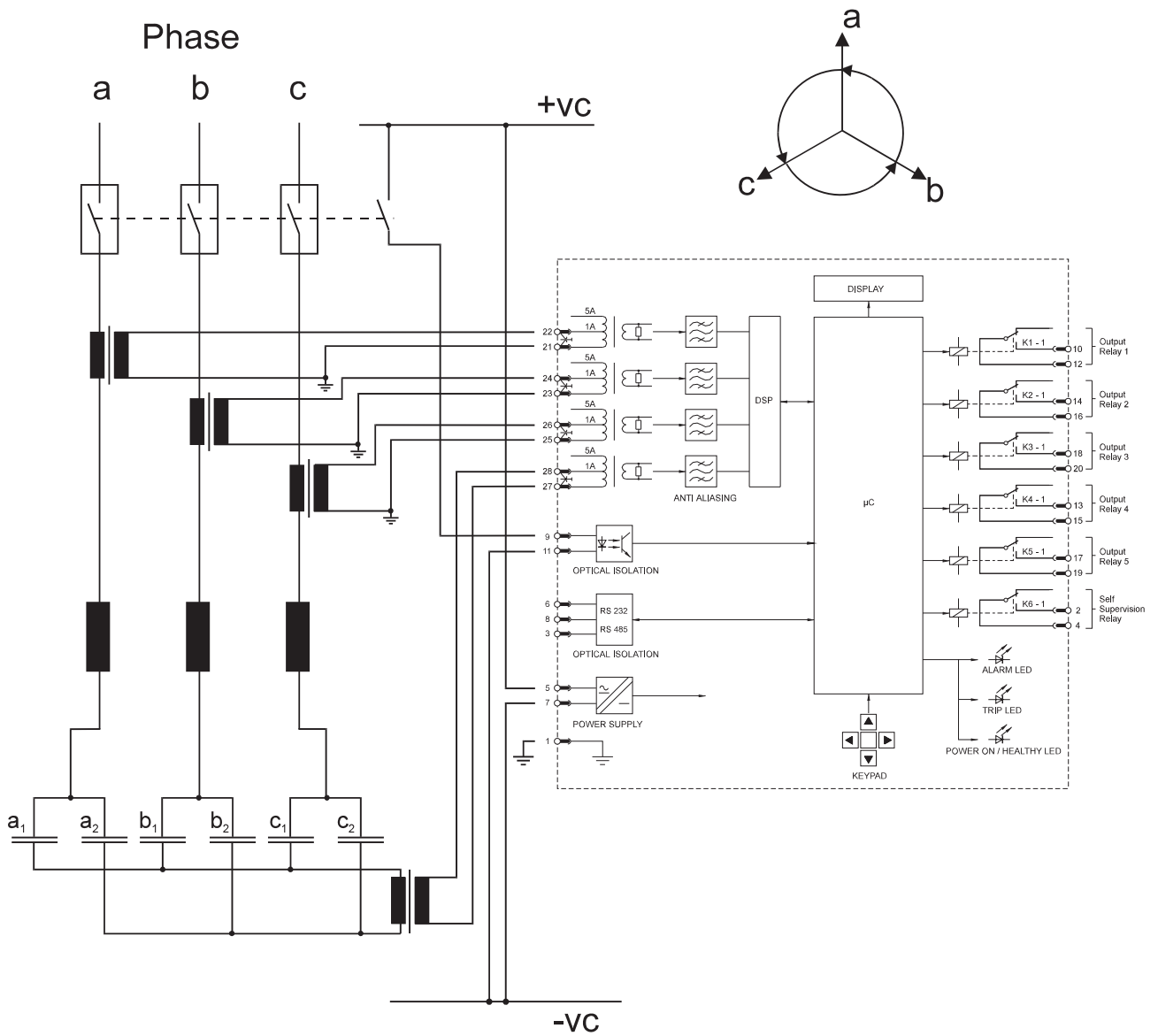
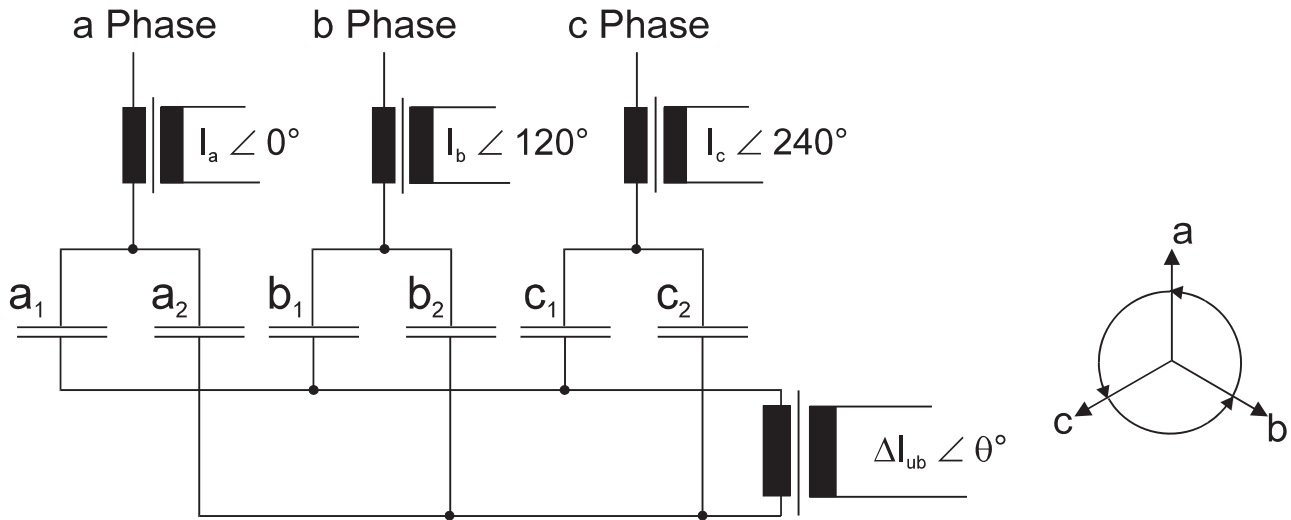

Figure 7: Element Failure in a Double Star Connected Capacitor Bank



A) Element failure on internally or externally fused capacitor units

With respect to the phase angle of I_a

- If $\angle 0^\circ$ this indicates element failure in capacitor a_2
- If $\angle 60^\circ$ this indicates element failure in capacitor c_1
- If $\angle 120^\circ$ this indicates element failure in capacitor b_2
- If $\angle 180^\circ$ this indicates element failure in capacitor a_1
- If $\angle 240^\circ$ this indicates element failure in capacitor c_2
- If $\angle 300^\circ$ this indicates element failure in capacitor b_1

B) Element failure on unfused capacitor units

With respect to the phase angle of I_a

- If $\angle 0^\circ$ this indicates element failure in capacitor a_1
- If $\angle 60^\circ$ this indicates element failure in capacitor c_2
- If $\angle 120^\circ$ this indicates element failure in capacitor b_1
- If $\angle 180^\circ$ this indicates element failure in capacitor a_2
- If $\angle 240^\circ$ this indicates element failure in capacitor c_1
- If $\angle 300^\circ$ this indicates element failure in capacitor b_2



Electrical Distributors

Figure 8: Typical Wiring Diagram for an H-Bridge Capacitor / Filter Bank

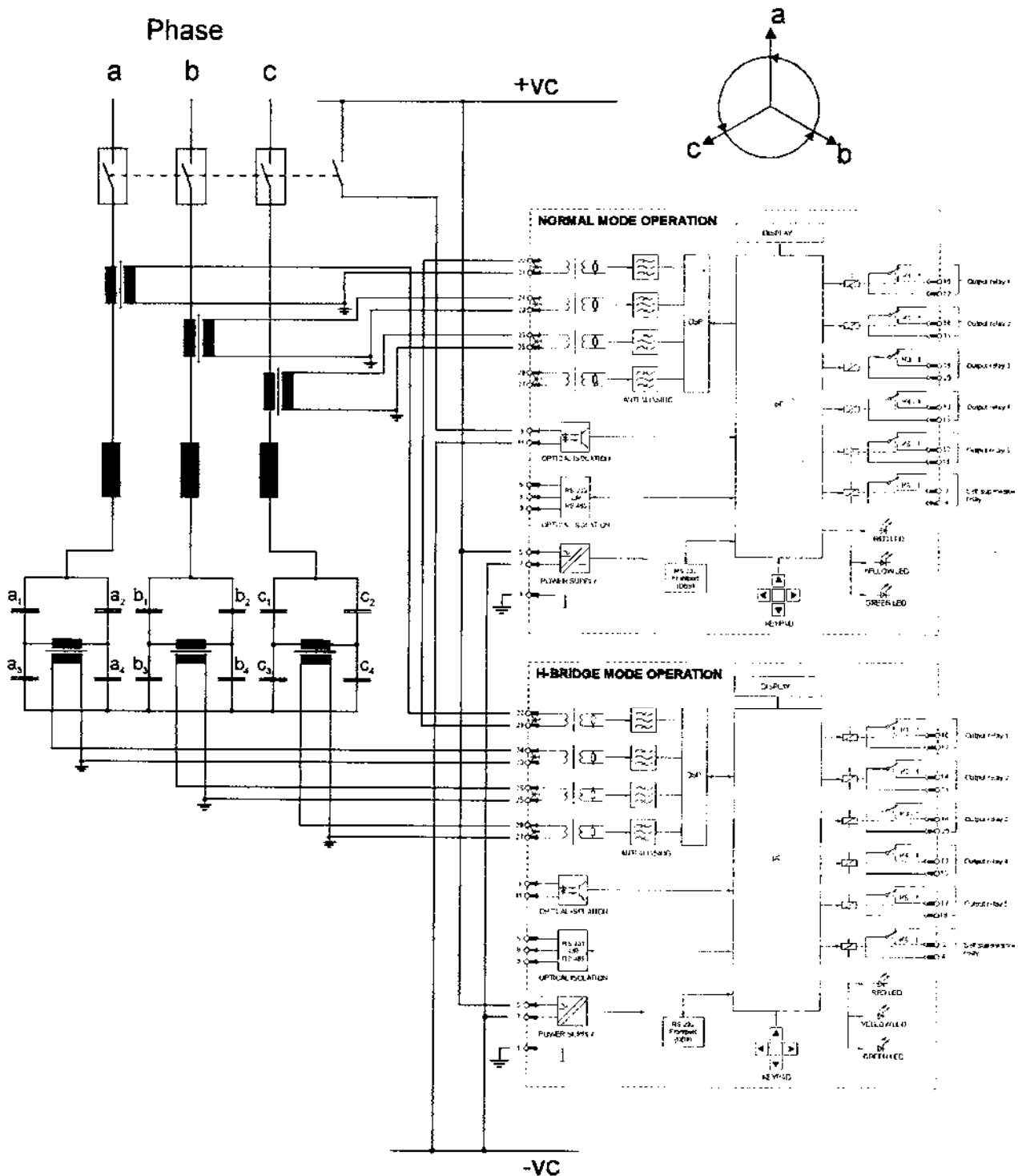
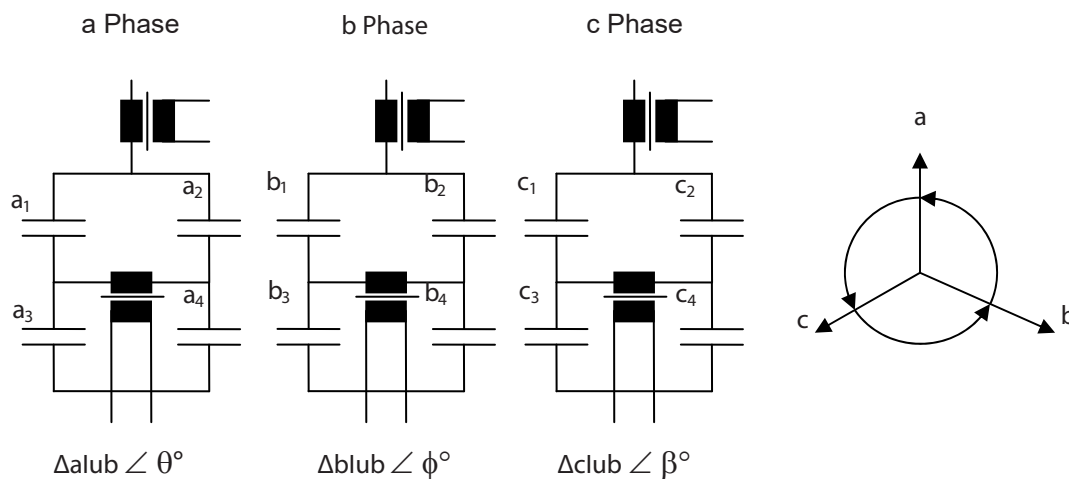

Figure 9: Element Failure in an H- Bridge Connected Capacitor Bank



Element failure on internally or externally fused capacitor units
With respect to the phase angle of I_a

- If $\square \square 0^\circ$ this indicates element failure in capacitor a2 or a3
- If $\square \square 180^\circ$ this indicates element failure in capacitor a1 or a4
- If $\square \square 120^\circ$ this indicates element failure in capacitor b2 or b3
- If $\square \square 300^\circ$ this indicates element failure in capacitor b1 or b4
- If $\square \square 240^\circ$ this indicates element failure in capacitor c2 or c3
- If $\square \square 60^\circ$ this indicates element failure in capacitor c1 or c4

Element failure on unfused capacitor units
With respect to the phase angle of I_a

- If $\square \square 0^\circ$ this indicates element failure in capacitor a1 or a4
- If $\square \square 180^\circ$ this indicates element failure in capacitor a2 or a3
- If $\square \square 120^\circ$ this indicates element failure in capacitor b1 or b4
- If $\square \square 300^\circ$ this indicates element failure in capacitor b2 or b3
- If $\square \square 240^\circ$ this indicates element failure in capacitor c1 or c4
- If $\square \square 60^\circ$ this indicates element failure in capacitor c2 or c3



Figure 10: Output Relay 1 to 5 Configuration

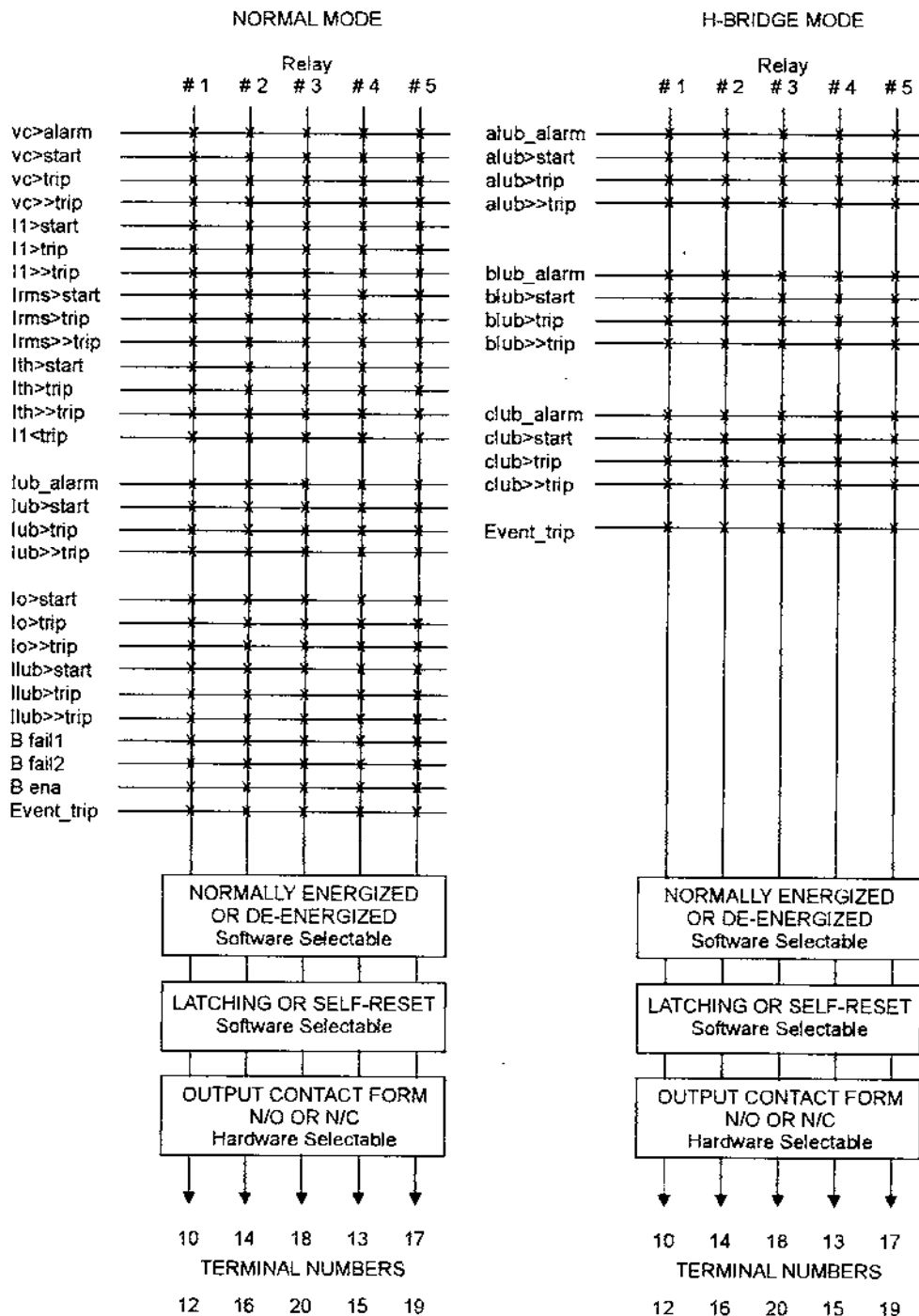

Note: x is a software switch to direct any of the software outputs to any of the output relays (#1 to #5)



Electrical Distributors

Strike Technologies

Co. Reg No: 1979/00174407

VAT No: 4200116657

Gauteng Office

106 Richards Drive
Midrand
1685

P O Box 1810
Halfway House
1685

Tel +27 (0)11 315 0815
Fax +27 (0)11 315 2559

Cape Town Branch

19 Mansell Road
Killarney Gardens
Killarney
7440

Tel +27 (0)21 557 5770
Fax +27 (0)21 557 5838

Durban Branch

4 Walter Place
Mayville
4091

P O Box 30167
Mayville
4058

Tel +27 (0)31 240 0700
Fax +27 (0)31 240 0750

www.strike.co.za

